

17305

21819

4 Hours / 100 Marks

Seat No.

--	--	--	--	--	--	--	--	--

- Instructions :**
- (1) All Questions are *compulsory*.
 - (2) Illustrate your answers with neat sketches wherever necessary.
 - (3) Figures to the right indicate full marks.
 - (4) Assume suitable data, if necessary.
 - (5) Mobile Phone, Pager and any other Electronic Communication devices are not permissible in Examination Hall.

- | | Marks |
|--|--------------|
| 1. (a) Draw conventional representation of any SIX of the following : | 12 |
| (i) Removed section | |
| (ii) Internal thread | |
| (iii) Cast iron | |
| (iv) Splined shaft | |
| (v) Globe valve | |
| (vi) Counter sunk | |
| (vii) Piper or tubing | |
| (viii) Helical spring with circular cross-section | |
| (b) Attempt any TWO : | 8 |
| (i) Draw the symbols for the following : | |
| (1) Double V butt weld. | |
| (2) Single bevel butt weld. | |
| (3) Spot weld. | |
| (4) Fillet weld with convex finish. | |

(ii) State the meaning of following symbol shown in Fig. No. 1.

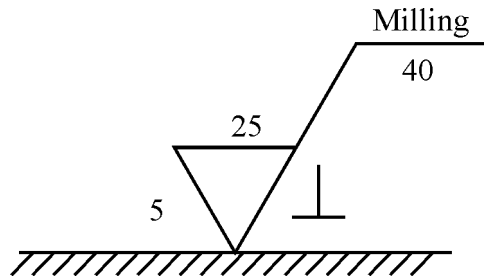

Fig. No. 1

(iii) The shaft has a size of $35^{-0.02}_{-0.04}$ & hole size of $35^{+0.02}_{+0.00}$. Find the allowances to determine type of fit between them.

2. (a) Fig No. 2 shows front view, Auxiliary view and incomplete side view. Complete the side view using first angle method. 12

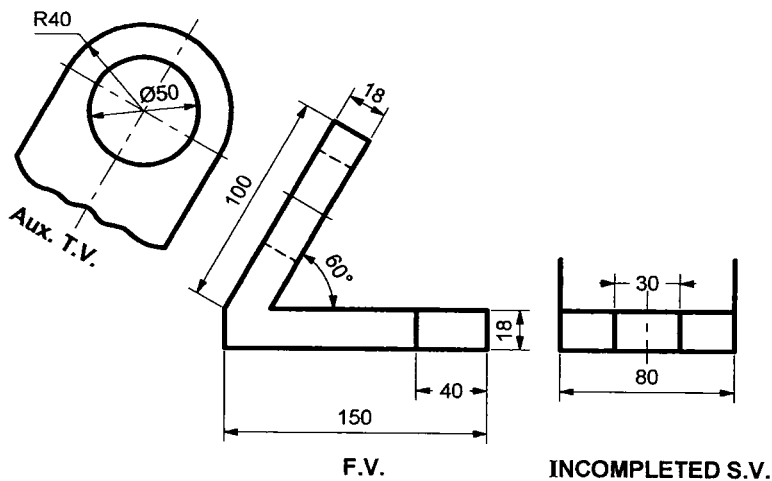

Fig. No. 2

(b) Attempt any TWO of the following :

8

- (i) Represent the welding drawing of two shaft with equal diameter welded end to end by means of square butt weld with convex counter of site.
- (ii) Draw the symbols of following features which are controlled in geometrical tolerance.

- (1) Cylindricity
- (2) Angularity
- (3) Profile of any line
- (4) Flatness

(iii) What is the meaning of symbol at x & y as shown in Fig. No. 3 ?

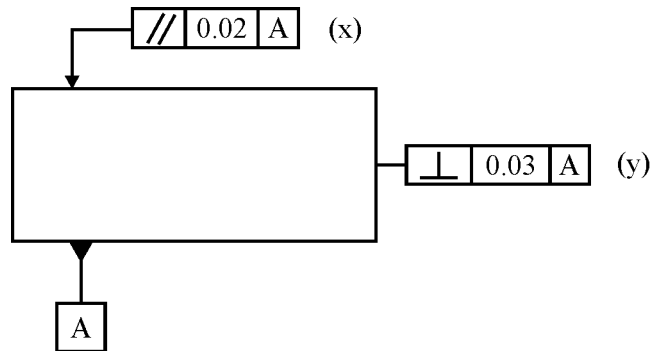

Fig. No. 3

3. Attempt any TWO of the following :

20

- (a) A vertical square prism, base 50 mm side & height 90 mm is completely penetrated by a horizontal square prism, base 35 mm side & axis length 90 mm so that their axes are 60 mm apart. The axis of horizontal prism is parallel to VP, while faces of both prism are equally inclined to VP. Draw projection of prism showing lines of intersection.
- (b) A vertical cylinder of 75 mm diameter is penetrated by another cylinder of 50 mm diameter. The axis of which is parallel to both HP & VP. The two axes are 9 mm apart. Draw the projection of two cylinder showing curve of intersection. The length of both cylinder is 100 mm.
- (c) A cone with base diameter 70 mm & axis height 65 mm is kept on HP on its base. It is penetrated by a horizontal cylinder of diameter 35 mm with its axis parallel to VP & intersecting axis of cone at distance of 20 mm above base of cone. Draw projection of solid showing curve of intersection.

P.T.O.

4. Attempt any ONE :

- (a) Fig. No. 4 shows details of screw jack. Draw sectional FV & TV of assembly. Prepare bill of material. Indicate type of fit.

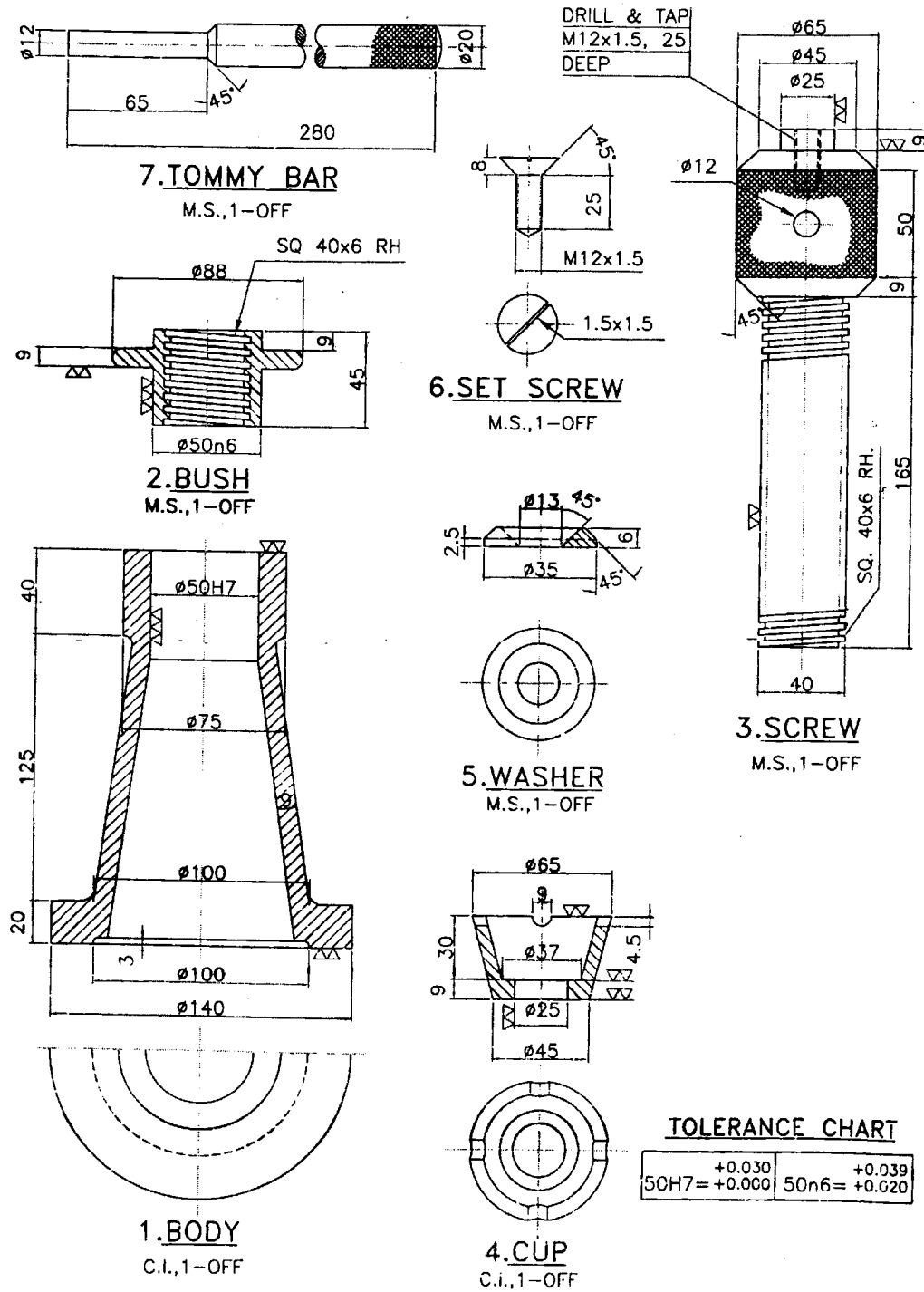

Fig. No. 4

(b) Fig. No. 5 shows details of lathe tool post. Draw sectional FV & TV of the assembly. Prepare bill of material. Indicate type of fit.

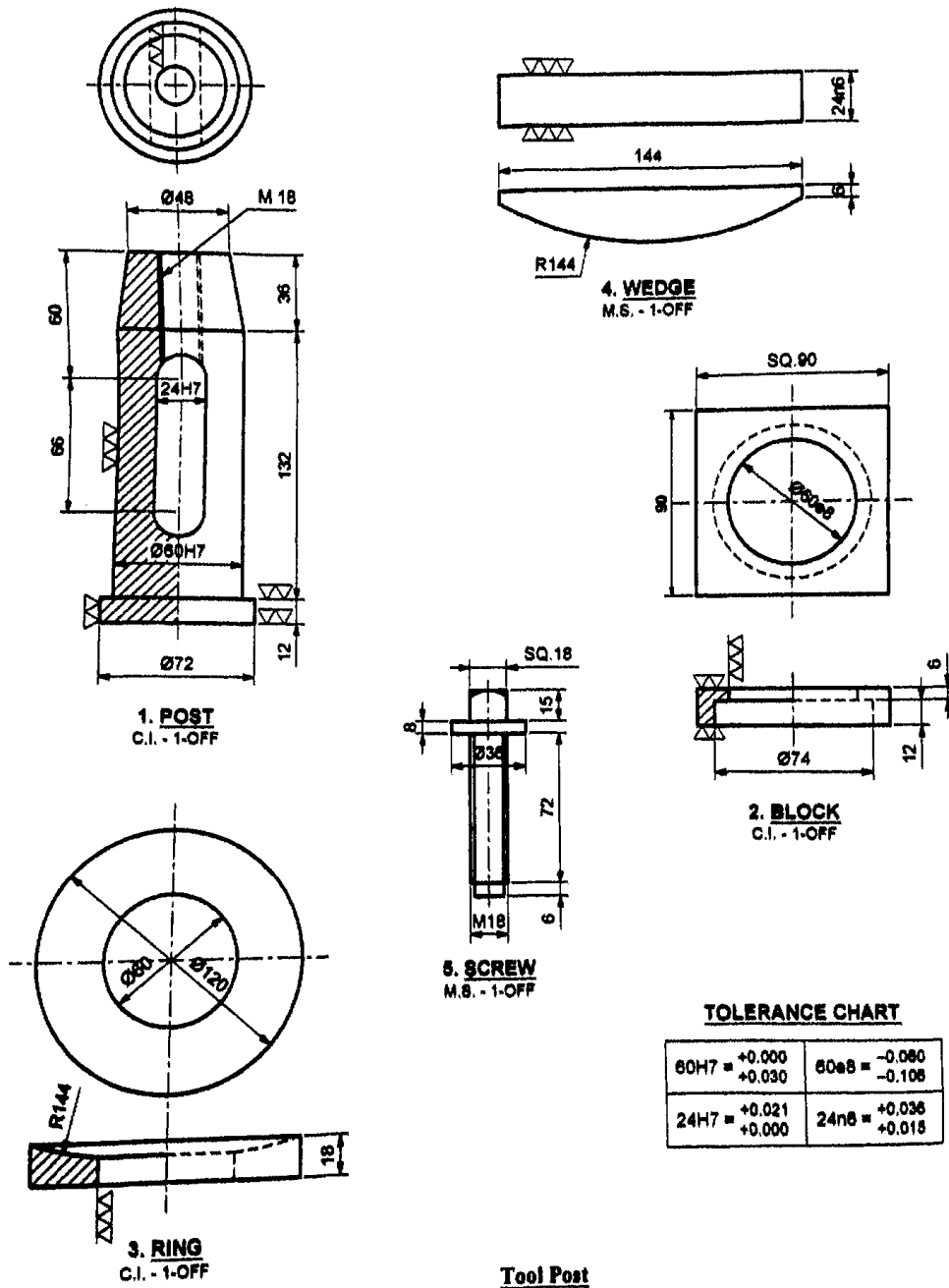
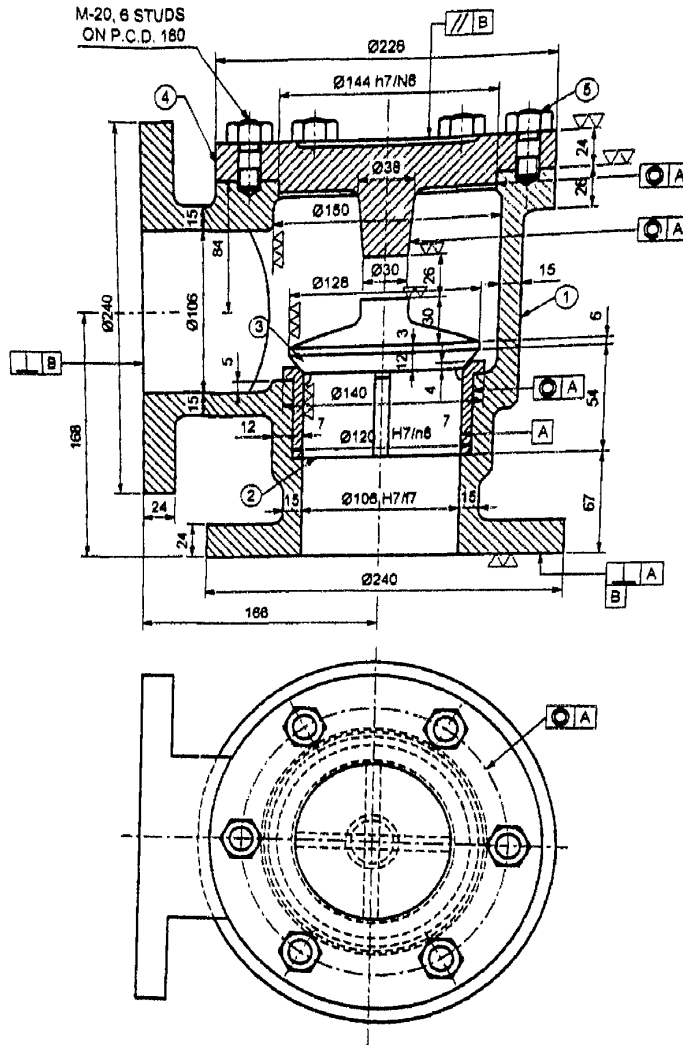

Fig. No. 5

5. Attempt any ONE :

(a) Fig. No. 6 shows assembly of Non-Return valve. Draw detailed drawing of following :

- (i) Body – sectional FV & TV.
- (ii) Valve – FY & TV.
- (iii) Valve seat – FV & TV.
- (iv) Cover – FV & TV.



Fit Chart

106H7/f7 = Clearance Fit
144H7/n6 = Clearance Fit
120H7/k6 = Clearance Fit

Part List

Part No.	Part Name	Material	Qty.
1	Body	C.I.	1
2	Valve Seat	G.M.	1
3	Valve	G.M.	1
4	Cover	C.I.	1
5	Stud with Nut	M.S.	4

Fig. No. 6

(b) Fig. No. 7 shows assembly of foot-step bearing. Draw the detailed drawing of following.

- (i) Body : Sectional FV & TV
- (ii) Bush : FV & TV
- (iii) Shaft : FV & TV
- (iv) Disc : FV & TV

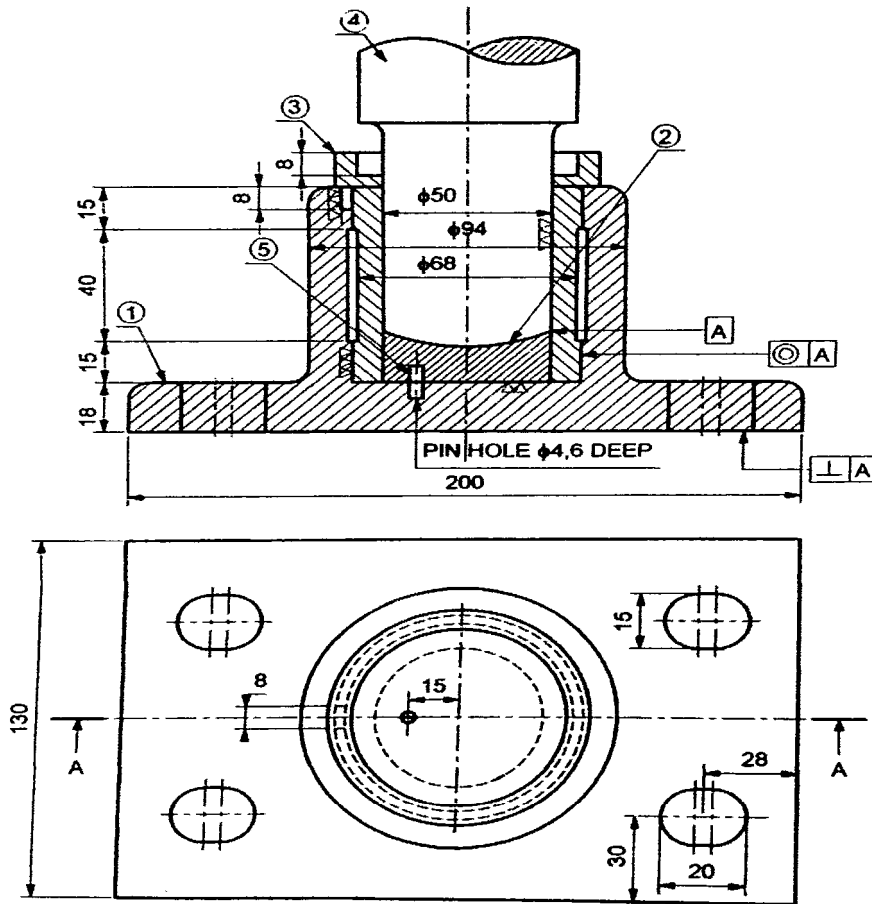

Part List

Part No.	Part Name	Material	Qty.
1	Body	C.I.	1
2	Disc	G.M.	1
3	Bush	G.M.	1
4	Shaft	M.S.	1
5	Pin	M.S.	1

Fig. No. 7

