

17536

21819

3 Hours / 100 Marks

Seat No.

--	--	--	--	--	--	--	--	--

- Instructions :**
- (1) All Questions are *compulsory*.
 - (2) Answer each next main Question on a new page.
 - (3) Illustrate your answers with neat sketches wherever necessary.
 - (4) Figures to the right indicate full marks.
 - (5) Assume suitable data, if necessary.
 - (6) Mobile Phone, Pager and any other Electronic Communication devices are not permissible in Examination Hall.

Marks

1. (A) Attempt any THREE of the following :

12

- (a) For a control system, characteristics equation is given by
$$S^5 + S^4 + 3S^3 + 9S^2 + 16S + 10 = 0.$$

Determine stability using Routh criteria.
- (b) Draw the block diagram of PLC and state the function of each block.
- (c) Give classification of control system & define linearity in control system.
- (d) State the principle of ON-OFF control. Write it's standard equation & define neutral zone.

(B) Attempt any ONE of the following :

6

- (a) Explain CPU & Memory related to CPU used in PLC.

[1 of 4]

P.T.O.

- (b) Determine the transfer function of the given block diagram using block reduction rules.

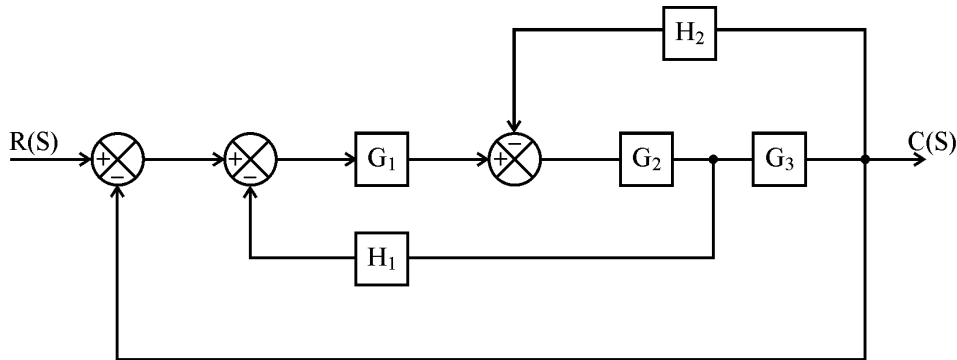

2. Attempt any TWO of the following :

16

- (a) For given transfer function

$$\text{T.F.} = \frac{10(S + 8)}{S(S + 4)(S^2 + 6S + 25)}$$

Find :

- (i) Poles
 - (ii) Zeros
 - (iii) Characteristic equation
 - (iv) Order of system
 - (v) Type of control system and plot the S-plane with poles, zeroes for the system.
- (b) A Unity Feedback system has

$$G(S) = \frac{40(S + 2)}{S(S + 1)(S + 4)}$$

Determine :

- (i) The error co-efficients &
 - (ii) Error for ramp input with magnitude 4.
- (c) Draw ladder diagram for 2 motor operation for following condition :
- (i) Start push button start motor M_1 & M_2 .
 - (ii) Stop push button stop motor M_1 first & after 10 seconds motor M_2 .

3. Attempt any FOUR of the following :**16**

- (a) Find the transfer function of closed loop control system with negative feedback.
- (b) Explain the benefits of PLC. (any four)
- (c) Determine the stability of the closed loop unity feedback system using Routh criteria :

$$G(S) = \frac{2}{S(S + 1)(S + 2)}$$

- (d) Define control system. Compare open loop & closed loop control system. (any six)
- (e) Explain :
 - (i) Scanning cycle
 - (ii) Speed of execution

4. (A) Attempt any THREE of the following :**12**

- (a) Draw block diagram of process control system & describe the need of controller.
- (b) List any four specification of discrete DC input module.
- (c) List different input devices & output devices use in PLC.
- (d) Draw the time response of second order control system for underdamp and overdamp conditions.

(B) Attempt any ONE of the following :**6**

- (a) List the timer instruction of PLC. Explain any one of them in details.
- (b) Explain PI control action. State its equation. State advantages of PI control. (any two)

P.T.O.

5. Attempt any TWO of the following :**16**

- (a) Describe sourcing & sinking concept in DC input module in PLC.
- (b) A unity feedback control system has

$$G(S) = \frac{26}{S(S + 5)}$$
 if step input is given to the system.

Calculate :

- (i) Rise time
- (ii) Damping ratio
- (iii) Peak overshoot
- (iv) Settling time
- (c) A system has $G(S) = \frac{K(5 + 13)}{S(S + 3)(S + 7)}$

where K is positive.

Determine the range of K value for system stability.

6. Attempt any FOUR of the following :**16**

- (a) Compare P control action with PID control action. (any four)
- (b) State advantages & disadvantages of Routh's Stability criteria.
- (c) Draw & explain AC discrete output module.
- (d) Explain PD control action. State advantages of PD control. (any two)
- (e) Define servo system. Draw & label the functional block diagram of DC servo system.
-