



Model Answers
Winter – 2018 Examinations
Subject & Code: Switchgear & Protection (17508)

Important Instructions to examiners:

- 1) The answers should be examined by key words and not as word-to-word as given in the model answer scheme.
- 2) The model answer and the answer written by candidate may vary but the examiner may try to assess the understanding level of the candidate.
- 3) The language errors such as grammatical, spelling errors should not be given more importance (Not applicable for subject English and Communication Skills).
- 4) While assessing figures, examiner may give credit for principal components indicated in the figure. The figures drawn by candidate and model answer may vary. The examiner may give credit for any equivalent figure drawn.
- 5) Credits may be given step wise for numerical problems. In some cases, the assumed constant values may vary and there may be some difference in the candidate's answers and model answer.
- 6) In case of some questions credit may be given by judgement on part of examiner of relevant answer based on candidate's understanding.
- 7) For programming language papers, credit may be given to any other program based on equivalent concept.



Model Answers

Winter – 2018 Examinations

Subject & Code: Switchgear & Protection (17508)

- 1 a) Attempt any **THREE** of the following: 12
- 1 a) i) Explain current limiting reactor.
- Ans:**
- Current Limiting Reactor:**
- A Reactor is a coil of number of turns designed to have large inductance with negligible ohmic resistance connected in series with equipment to limit the short circuit current. 1 mark
- Generally reactance of the system under fault condition is low and fault currents may rise to dangerously high values. In order to limit the fault current to reasonable magnitudes which the CB can handle, additional reactances (reactors) are connected in series with system at suitable points. These reactors are called “Current Limiting Reactors”. 2 marks
- Classification of reactors :**
- 1) Generator reactors
 - 2) Feeder reactors 1 mark
 - 3) Busbar reactors
 - i) Ring Systems
 - ii) Tie bar system
- 1 a) ii) What are causes of faults in power system? State any four harmful effects of faults.
- Ans:**
- Causes of faults in power systems:**
- 1) Over voltages due to direct lightning strokes.
 - 2) Over voltages due to switching surges.
 - 3) Falling of external conducting objects, tree branches etc. on conducting lines. ½ mark for each cause maximum 2 marks,
 - 4) Accumulation of dust, dirt etc. on exposed components as lines, insulators etc.
 - 5) Perching of birds on lines, insulators or other components.
 - 6) Ill-maintained sections of the power systems.
 - 7) Heavy unbalanced loading on three phase lines even for short times.
 - 8) Prolonged unbalanced loading conditions leading to overheating (due to harmonics).
 - 9) Failure of joints.
 - 10) Open circuited line or broken conductors.
 - 11) Mechanical damage to components of the power systems.
 - 12) Unusually severe atmospheric conditions as storm, rains, too high humidity,
 - 13) Defective/improper selection of components used and faulty design of the power system sections.
 - 14) Failure of insulation of components and equipment parts.
 - 15) Accidents.
 - 16) Over temperature.
 - 17) Excessive internal and external stresses.
- Effects of faults:**
- 1) Heavy short circuits lead to damage to equipment mechanically and electrically. ½ mark for each effect maximum 2 marks
 - 2) Arcing during faults leads to fire hazards.
 - 3) Heavy drop in the supply voltage to loads leading to their mal-operation.



Model Answers
Winter – 2018 Examinations
Subject & Code: Switchgear & Protection (17508)

- 4) Overheated machines due to unbalanced supply voltages.
- 5) Loss of revenue to supply agency owing to stoppage of supply.
- 6) Loss of system stability due to generators losing synchronism.
- 7) Distress load shedding.

1 a) iii) Define:

- (1) Plug setting multiplier
- (2) Time setting multiplier

Ans:

Plug setting multiplier (PSM):

It is related to the current setting of the overcurrent relays.

The plug setting multiplier is defined as the ratio of the 'transformed fault current on the relay side' to the 'relay pickup current'. 1 mark

$$\text{PSM} = \frac{\text{transformed fault current on CT secondary side}}{\text{relay current setting}} \quad \text{1 mark}$$

$$= \frac{\text{fault current on CT primary side (i.e line fault current)}}{\text{relay current setting} \times \text{CT ratio}}$$

Time setting multiplier (TSM):

It is related to the operating time of the relay during faults. The angular distance through which the relay disc travels during faults before the trip contacts close is varied to get different times of operation of the relay. This is time setting. These times of motion of the disc are set in 10 steps starting with maximum time setting of 1 (when disc is set farthest) to minimum (when disc is nearest) of 0 (instantaneous). For example if the angular travel from trip contacts is set to maximum then TSM =1, then for a particular PSM if the operating time of relay is 1 second then for the same PSM if the TSM is set to 0.4 then the time of operation will be (1 second x TSM) 1 mark

$$= 1 \times 0.4 = 0.4 \text{ seconds.} \quad \text{1 mark}$$

Thus TSM is used to define the steps for time setting of relay operation.

1 a) iv) Explain the phenomenon of lightning.

Ans:

Phenomenon of lightning:

An electric discharge between cloud and earth, between clouds or between the charge centres of the same cloud is known as "Lightning". 1 mark for definition

Lightning takes place when the clouds acquire charge. During the uprush of warm moist air from earth, the friction between the air and the tiny particles of water causes building up of charges. When drops of water are formed, the larger drops become positively charged and the smaller drops become negatively charged. When the drops of water accumulate, they form clouds and hence cloud may possess either a positive or a negative charge, depending upon the charge of water drops they contain. The charge on a cloud may become so great that it may discharge to another cloud or earth through air medium, after its electrical breakdown. Such a discharge is called as lightning. 1 mark for process of charging

When the charged cloud passes over the earth, it induces equal and opposite charge on



Model Answers
Winter – 2018 Examinations
Subject & Code: Switchgear & Protection (17508)

the earth below. As the charge acquired by the cloud increases, the potential between cloud and earth increases and therefore the potential gradient in the air between them increases. When the potential gradient becomes more than the dielectric strength of the air medium, the electrical breakdown of the air takes place and the lightning stroke starts. The lightning stroke mechanism is as follows:

- (i) As soon as the air near the cloud breaks down, a streamer called “leader streamer” or “pilot streamer” starts from cloud towards the earth and carries charge with it. So far the cloud feeds enough charge to maintain the gradient above the dielectric strength of air at the tip of the leader streamer; the leader streamer continues its journey towards the earth.
- (ii) As the leader streamer moves towards earth, it is accompanied by points of luminescence which travel in jumps giving rise to stepped leaders. The stepped leaders have sufficient luminosity and give rise to first visual phenomenon of discharge.
- (iii) As the leader streamer reaches near earth, a return streamer shoots up from the earth to the cloud, following the same ionized path as that of leader streamer. This phenomenon causes a sudden spark which we call lightning.

2 marks for
Stroke
mechanism

1 b) **Attempt any ONE of the following:**

06

- 1 b) i) A station operating at 33kV is divided into section P and Q. Section P consist of 3 generators 15MVA each having reactance of 15% and section Q is fed from grid through a 750MVA transformer of 8% reactance. The C.B's have each a rupturing capacity 750 MVA. Determine the reactance of the reactor to prevent the breakers being overloaded if a symmetrical short circuit occurs on an out going feeder connected to P.

Ans:

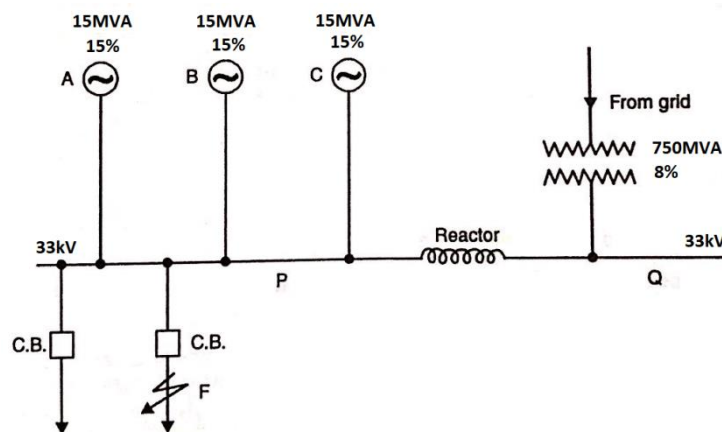

1 mark for
network
diagram

Figure shows the single-line diagram of the network. Suppose the fault occurs at point F on an outgoing feeder connected to section P. As per the given condition, the short circuit MVA at F should not exceed 750 MVA.

Since the maximum power rating is 750MVA of transformer, let us choose 750MVA as base MVA.

\therefore Base MVA = 750MVA

\therefore %Reactance of each of the generator on the base MVA = $\frac{750}{15} \times 15 = 750\%$

1 mark for
reactances on
base MVA



Model Answers

Winter – 2018 Examinations

Subject & Code: Switchgear & Protection (17508)

$$\therefore \% X_A = \% X_B = \% X_C = 750\%$$

% Reactance of the transformer on base MVA is

$$\% X_T = \frac{750}{750} \times 8 = 8\%$$

Suppose the required reactance of the reactor is $X\%$ on 750MVA base. When the fault occurs at point F, the reactance diagram at the selected base MVA will be as shown in the following figure.

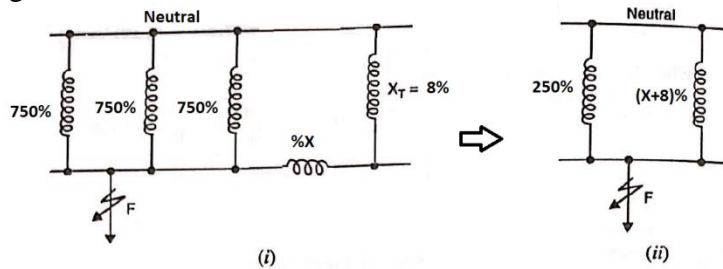

1 mark for reactance diagram

The reactances of the three generators are in parallel & their equivalent reactance is given by, $= \frac{750}{3} = 250\%$

The circuit is then simplified as shown in the figure.

Total percentage reactance from generator neutral to fault point F is,

$$= \frac{(250)(X+8)}{250+X+8}$$

Now fault MVA at F should not exceed 750MVA, otherwise the circuit breakers will be overloaded.

$$\text{Fault MVA} = \text{Base MVA} \times \frac{100}{\text{Required \% Reactance}}$$

$$750 = 750 \times \frac{100}{\text{Required \% Reactance}}$$

1 mark

\therefore Required % Reactance = 100%

This means that total % Reactance from generator neutral to fault point F should be 100%

$$\text{i.e } 100 = \frac{(250)(X+8)}{250+X+8}$$

$$\frac{250+X+8}{2.5} = X + 8$$

$$100 + 0.4X + 3.2 = X + 8$$

$$100 + 3.2 - 8 = X - 0.4X = 0.6X$$

$$X = 158.67\%$$

1 mark

$$\text{But \% Reactance} = \frac{(\text{Base kVA})(\text{Reactance in } \Omega)}{10(\text{kV})^2}$$

$$= \frac{(\text{Base MVA} \times 1000)(X \text{ in } \Omega)}{10(\text{kV})^2}$$

$$158.67 = \frac{750 \times 1000 \times X}{10(33)^2}$$

$$X = \frac{158.67 \times 10 \times 33^2}{750 \times 1000}$$

\therefore Reactance of Reactor in ohm = $X = 2.3039\Omega$

1 mark

- 1 b) ii) A 3 ϕ , 66/11 kV, star-delta connected transformer is protected by Merz-Price system. The CTs on LV side have a ratio of 400/5. Find the ratio of the CTs on the HV side.

Ans:

The CTs on LV side are connected in star as transformer windings are in delta.

Model Answers

Winter – 2018 Examinations

Subject & Code: Switchgear & Protection (17508)

Whereas those on HV side are in delta as the transformer windings are in star on that side.

Assume CT line current on LV side to be 5 A and then that on HV side will also be 5 A. But HV side CTs are in delta. Hence the HV side CT current will be (CT line current)/ $\sqrt{3} = 5/\sqrt{3}$ A. 2 marks

Assume line current (for convenience) of 400 A on LV side (delta side) of transformer. When transformed to HV side the line current will be I_{Lht} given by

$$\sqrt{3} \times 66 \times I_{Lht} = \sqrt{3} \times 11 \times 400$$

$$I_{Lht} = (11/66) \times (400) = 66.67 \text{ A.}$$
2 marks

On HV side the CT primary current is 66.67 A and CT secondary current is $5/\sqrt{3}$ A, hence the CT ratio is $66.67/(5/\sqrt{3}) = (66.67\sqrt{3}/5) = 115.47/5$. 2 marks

2 Attempt any FOUR of the following: 16

2 a) Define:

- i) Arc voltage,
- ii) Recovery voltage,
- iii) Restriking voltage,
- iv) RRRV

Ans:

- i) **Arc Voltage:** The voltage existing between the circuit breaker contacts during arcing is called as the arc voltage. It is low value compared to the system rated voltage. Normally it is around 3% to 5% of the rated system voltage. 1mark for each definition
- ii) **Recovery voltage:** The normal power frequency voltage that appears across the contacts after the arc is finally extinguished and the transients have fully disappeared is the recovery voltage.
- iii) **Restriking voltage:** The transient voltage that appears across the contacts of the circuit breaker at the instant of the arc getting extinguished is called as the restriking voltage.
- iv) **RRRV:** The RRRV (**R**ate of **R**ise of the **R**estriking **V**oltage) is defined as the slope of the steepest tangent to the restriking voltage curve. It is expressed in volts per micro-second.

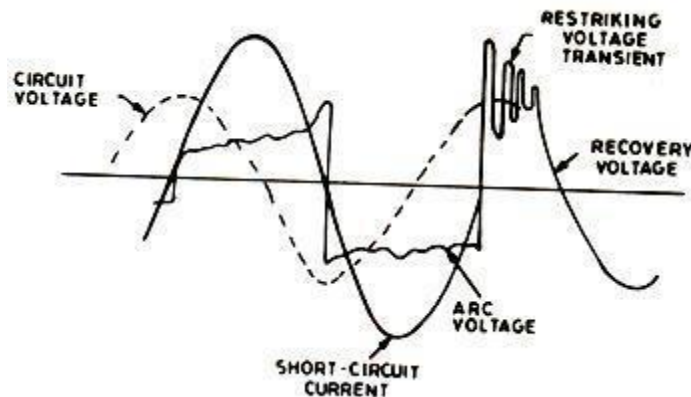

2 b) Explain construction and working of SF₆ circuit breaker.

Model Answers

Winter – 2018 Examinations

Subject & Code: Switchgear & Protection (17508)

Ans:

Construction:

A sulphur hexafluoride (SF₆) circuit breaker consists of fixed and moving contacts enclosed in a chamber. The chamber is called arc interruption chamber, which contains the sulphur hexafluoride (SF₆) gas. This chamber is connected to sulphur hexafluoride (SF₆) gas reservoir. A valve mechanism is there to permit the gas to the arc interruption chamber. When the contacts of breaker are opened, the valve mechanism permits a high-pressure sulphur hexafluoride (SF₆) gas from the reservoir to flow towards the arc interruption chamber.

2 marks for construction

The fixed contact is a hollow cylindrical current carrying contact fitted with an arcing horn. The moving contact is also a hollow cylinder with rectangular holes in the sides. The holes permit the sulphur hexafluoride gas (SF₆) gas to let out through them after flowing along and across the arc. The tips of fixed contact, moving contact and arcing horn are coated with a copper-tungsten arc-resistant material. Since sulphur hexafluoride gas (SF₆) gas is costly, it is reconditioned and reclaimed using the suitable auxiliary system after each operation of the breaker.

Working of SF₆ circuit breaker:

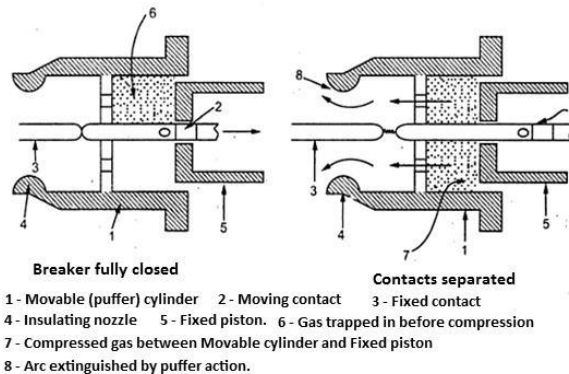

1 mark for diagram

1 mark for working

Single pressure puffer type SF₆ circuit breaker

Gas is compressed by the moving cylinder and is released through the nozzle and rapidly absorbs the free electrons to extinguish the arc formed.

The moving cylinder (1) connected to moving contact (2) against the fixed piston (5). Due to relative motion between (1) and (5) the gas gets compressed in enclosure (6) and is released through nozzle for arc extinction. This happens by puffing action. At current zero the diameter becomes too small and arc gets extinguished.

OR

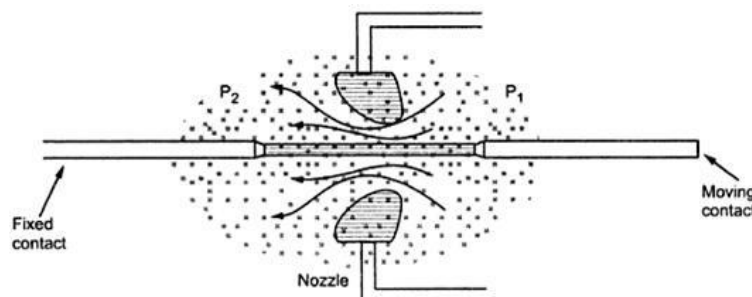

Double pressure type breaker:

Model Answers
Winter – 2018 Examinations
Subject & Code: Switchgear & Protection (17508)

Here the gas is made to flow from area P_1 to P_2 through a convergent-divergent nozzle. The flowing gas covers the arc. In the divergent section the speed of the gas is very high and carries away most of the heat and absorbs free electrons from the periphery of arc that results in the reduction of diameter of arc, which becomes nearly zero at current zero, leading to arc being extinguished. Finally the gas enters the contact space increasing the dielectric strength.

2 c) Explain working of surge absorber with neat diagram.

Ans:

Surge Absorber:

Voltage transients or surges on the power system may originate from switching or lightning. These surges set up traveling waves in the transmission lines. These traveling waves may reach the terminals of expensive equipment in power system and may cause damage to it.

This amount of damage caused by surges not only depends upon the amplitude of the surge but also upon the steepness of its wavefront. The steeper the wavefront of the surge, the more the damage caused to the equipment. To reduce the steepness of the wavefront of a surge generally, surge absorbers are used.

A surge absorber is a protective device, which reduces the steepness of wavefront of a surge by absorbing surge energy.

1 mark for definition

Some popular types of surge absorber used in power system are as under:

1. Condenser or capacitor surge absorber.
2. Inductor and resistance surge absorber.
3. Ferranti surge absorber.

Condenser or Capacitor Surge Absorber:

A condenser connected between the line and earth can act as a surge absorber. In Figure, a capacitor is used as surge absorber to protect the transformer winding.

1 mark for any one diagram

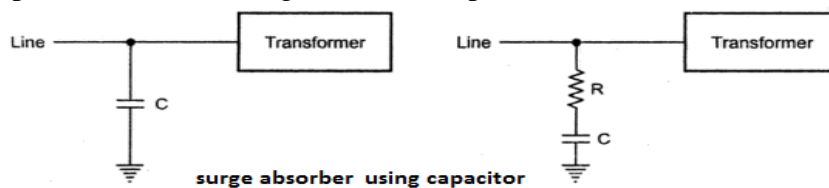

2 marks for working

Since the reactance of a condenser is inversely proportional to frequency, it will be low at high frequency and high at low frequency. The surges are of high frequency, therefore, the capacitor acts as a short circuit and passes them directly to earth. However, for power frequency, the reactance of the capacitor is very high and practically no current flows to the ground.

Inductor and Resistance Surge Absorber:

This type of surge absorber consists of a parallel combination of choke and resistance connected in series with the line.

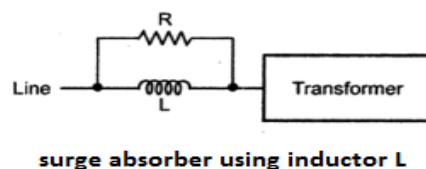

The choke offers high reactance to high frequencies ($X_L = 2 \pi f L$). The surges have

Model Answers
Winter – 2018 Examinations
Subject & Code: Switchgear & Protection (17508)

high frequencies therefore, are forced to flow through the resistance R where the surge energy is dissipated.

Ferranti Surge Absorber:

It consists of an air cored inductor connected in series with the line. The inductor is surrounded by but insulated from an earthed metallic cylinder called dissipator. This arrangement is equivalent to a transformer with short-circuited secondary.

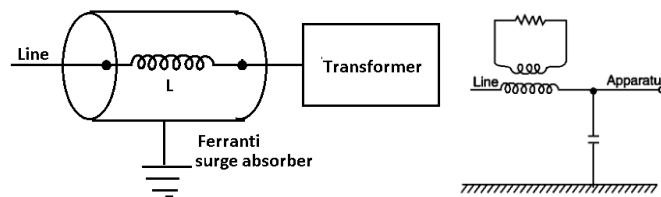

The inductor acts as the primary of transformer whereas the dissipator as the short-circuited secondary. The energy of the surge is consumed in the dissipator in form of heat due to transformer action. Generally, it is used for the protection of transformers.

- 2 d) Write down difference between equipment earthing and neutral earthing.

Ans:

Difference between Equipment earthing and Neutral earthing:

Sr. No.	Equipment earthing	Neutral earthing
1	Connection of the non-current carrying metallic parts of the electrical equipment to earth is called as equipment earthing.	Connection of the neutral point of three phase transformer, generators, motors etc. to earth is neutral earthing.
2	It is provided for protection of human being from electric shocks.	It is provided for eliminating arcing ground and over voltage surge.
3	It has nothing to do with stability	Stability of the system is increased.
4	Equipment earthing is provided through Pipe earthing, Plate earthing.	Neutral earthing is provided through solid earthing, resistance earthing and reactance earthing.
5	It does not provide any means for protection system against earth fault.	It provides suitable means for earth fault protection system.
6	It is an equipment earthing.	It is a source or system earthing.

1 mark for each of any four points = 4 marks

- 2 e) The current rating of a relay is 5A. PSM = 1.5, TSM = 0.5, C.T. ratio 500/5, fault current = 6000A. Determine the operating time of the relay at TSM = 1, operating time at various PSM are:

PSM	2	4	5	8	10	20
Operating time in sec	10	5	4	3	2.8	2.4

Ans:

Rated secondary current of C.T. = 5A

1 mark



Model Answers

Winter – 2018 Examinations

Subject & Code: Switchgear & Protection (17508)

Pick up current = $5 \times 1.5 = 7.5A$ 1 mark

Fault current in relay coil = $6000 \times \frac{5}{500} = 60A$

\therefore Plug setting multiplier (PSM) = $\frac{\text{fault current in relay coil}}{\text{pick-up current}}$

$= \frac{60}{7.5} = 8$ 1 mark

Corresponding to PSM of 8 (consider given table), the time of operation is 3 seconds. 1 mark

Actual relay operating time = $3 \times \text{time setting} = 3 \times 0.5 = 1.5 \text{ seconds}$

- 2 f) An 11kV, 100MVA alternator is grounded through a resistance of 4Ω . The CTs have a ratio 1000/5. The relay is set to operate when there is an out of balance current of 1 A. What percentage of alternator winding will be protected by the percentage differential protection?

Ans:

Let $x\%$ of winding be unprotected.

Earthing resistance $r = 4 \Omega$

Voltage per phase = $\frac{11 \times 1000}{\sqrt{3}} = 6350.8529 \text{ volts}$

Minimum fault current which will operate the relay = $\frac{1000}{5} \times 1.0 = 200A$ 1 mark

E.m.f. induced in $x\%$ winding = $V_{ph} \times \frac{x}{100} = \frac{6350.85(x)}{100} = 63.5085(x) \text{ volts}$ 1 mark

Earth fault current which $x\%$ winding will cause = $\frac{63.5085(x)}{r} = 15.88(x)$

This current must be equal to minimum fault current which will operate the relay.

$\therefore 15.88(x) = 200$

$\therefore x = 12.6 \%$

So percentage of winding protected = $100 - 12.6 = 87.4 \%$ 1 mark

- 3 **Attempt any FOUR of the following:** **16**

- 3 a) Describe the difference between fuse and MCCB.

Ans:

Difference between Fuse and MCCB:

Sr. No.	Fuse	MCCB
1	Fuse melts / fuses in case of excessive load.	MCCB trips off in case of excessive load.
2	Fuse needs to be replaced after every operation.	MCCB is to be just put ON after correcting the fault.
3	Porcelain base and top. Not attractive.	Compact, small and attractive.
4	Works on melting / fusing due to high temperature.	Works on bi-metal expansion or induced magnetism.
5	Relatively economical than	Relatively costlier than fuse.

1 mark for each of any four points = 4 marks



Model Answers
Winter – 2018 Examinations
Subject & Code: Switchgear & Protection (17508)

	MCCB.	
6	Simple in construction.	Complicated in construction.
7	Operating time is very small. (0.002 sec or so)	Operating time is comparatively large. (0.1 to 0.2 sec)
8	Risk in putting on the fuse element.(Unsafe)	No risk in putting “ON” the MCCB. (Safe).
9	Generally protects the load against short-circuit.	Generally protects the load against different types of faults.

3 b) Write down specification and applications of Air blast C. B. and Vacuum C. B.

Ans:

Specifications of Circuit Breaker:

- i) Service type: Indoor / Outdoor
- ii) No. of Poles: 1 or 3
- iii) Nominal System Voltage:
- iv) Highest System Voltage:
- v) Rated normal current;
- vi) Rated short-circuit breaking current (rms):
- vii) Rated short-circuit making current (rms):
- viii) Rated short-time current withstand capability for 3 sec:
- ix) Rated insulation level:
- x) S. C. Rating:
- xi) No. of breaks per phase:
- xii) Operating air / gas pressure:
- xiii) Nominal frequency

2 marks for
any four
specification
s

Applications:

Air Blast Circuit Breaker:

Air blast circuit breakers are used in electrical systems operating at 132kV and above upto 400kV.

1 mark

Vacuum Circuit Breaker:

Vacuum circuit breakers are used in electrical systems operating at 11kV, 25kV and 33kV.

1 mark

3 c) How can we use CT and PT for protection purpose?

Ans:

CT and PT for Protection purpose:

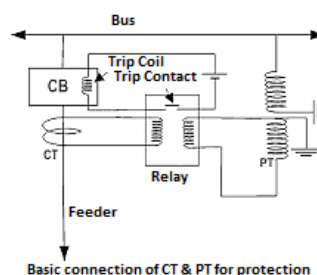

1 mark



Model Answers
Winter – 2018 Examinations
Subject & Code: Switchgear & Protection (17508)

Current transformer (CT) and Potential transformer (PT) are instrument transformers, which are used in conjunction with protective relays for protection purpose.

The CT has fewer number of turns (usually single turn or simply a conductor bar) on primary side and a large number of turns on the secondary side. Due to this difference in turns, a large current on primary side is transformed into current of low safe value on secondary side. The CT is connected with primary in series with power system component carrying large current and secondary winding feeds proportionately reduced current to protective relay.

Potential transformer (PT) has large number of turns on primary side and fewer number of turns on the secondary side. Therefore, it steps down the primary voltage to lower safe secondary voltage. The PT is connected with primary connected to high voltage system bus and secondary winding feeds proportionately reduced voltage to protective relay.

3 marks for
proper
explanation

Protective relay is a device that detects abnormal condition in electrical system by continuously measuring / monitoring the electrical quantities such as current, voltage etc., which are different under normal and fault conditions. The current, voltage and phase angle are the basic quantities which change during fault conditions. On the occurrence of fault, the system voltage and current get affected. The CT and PT provides the information about the changed system condition to the relay. The relay determines the faulty condition and operates the trip contact as shown in the figure. The trip circuit of circuit breaker is energised. The current flows through trip coil of CB and the circuit breaker is tripped (opened) to disconnect the faulty part of system from the healthy part. In this way the CT and PT can be used for protection purpose.

- 3 d) Write down limitation of differential protection of transformer.

Ans:

Limitations of differential protection of transformer:

- 1) Due to the magnetization characteristics of the CTs used, the ratio errors change with respect to the circulating currents.
- 2) The pilot wires used may vary in length due to which the unbalance in the secondary circuit parameter (resistance) is created that result in improper scheme.
- 3) During heavy short circuit conditions the high currents create saturation of the flux in core of CTs that lead to abnormal relaying or unexpected behavior of the relaying circuit.
- 4) Tap changing may lead to change in settings & improper operation.
- 5) Inrush of magnetizing current may lead to inadvertent operation & hence the settings are done for higher values of fault current (higher imbalance) due to which accuracy of sensing & operation is decreased.

1 mark for
each of any 4
limitations
= 4 Marks

- 3 e) State and explain the faults occur in the transformers.

Ans:

Sr. No.	Type of fault	Explanation
1	Earth fault	Due to breakdown of insulation between live



Model Answers
Winter – 2018 Examinations
Subject & Code: Switchgear & Protection (17508)

		conducting parts such as winding, terminals etc. and earthed metallic parts such as core, tank etc. the current is diverted to earth, causing earth fault. The causes of earth fault are: Electrical breakdown of insulation due to over-voltage surges produced by lightning or switching operations. <ul style="list-style-type: none">) Mechanical damage of insulation.) Electrical or mechanical breakdown of bushings) Insulation damage due to over-heating
2	Overloads/ Overheating	Sustained overloads cause additional losses in windings, causing over-heating of windings. Unbalanced loading cause additional magnetic losses leading to over-heating of core and other mechanical parts.
3	Incipient faults: Phase to Phase, Phase to ground, low oil level, decomposition of oil	Incipient faults are slowly developing faults, which if not attended in time, can lead to severe faults. Slow insulation degradation due to continuous over-heating. <ul style="list-style-type: none">) Reduction in oil level due to leakage, which leads to unequal cooling of transformer assembly, resulting unequal thermal expansion and stresses.) Degradation of oil over a period of service.
4	Saturation of magnetic core	Over-voltage conditions lead to saturation of cores. Since flux level is increased, the iron losses are increased.
5	Faults in tap changer	Mechanical problems in tap changer assembly lead to faults in tap changer.
6	Inter turn fault	When insulation breakdown of a winding takes place and few turns of the same winding are short-circuited, the inter-turn fault takes place.

1 mark for each of any four faults = 4 marks

4 a) **Attempt any THREE of the following:**

12

4 a) i) How the alternator can be protected from inter-turn fault?

Ans:

Inter-turn fault Protection:

Figure shows scheme for one phase only. It is identical for other phases.

Under normal working condition, the two currents in the stator winding sections (S_1 and S_2) are identical and by virtue of the cross connected CT secondaries, the relay current is zero, hence no relay operation. But when one of the windings is faulty (inter turn fault) its current differs and hence the two CT secondary currents are different, due which the difference current is diverted through the relay coil to operate it, leading to isolation of the alternator from the power system.

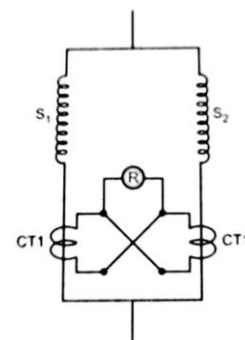

2 marks for description

2 marks for diagram

Model Answers
Winter – 2018 Examinations
Subject & Code: Switchgear & Protection (17508)

4 a) ii) Explain Horn-gap lightning arrester with neat sketch diagram.

Ans:

Horn Gap Type Lightning Arrester:

It consists of two horn shaped metal rods A and B separated by a small air gap. The horns are so connected that distance between them gradually increases towards the top. One end of the horn is connected to the line through resistance and choke coil while other end is effectively earthed. The resistance and inductance limits the current flow at normal frequency and does not allow the transients. Under normal operating conditions the gap G is non-conducting. On occurrence of over voltage, spark takes place across the gap and high voltage is diverted towards earth for safety of equipment. Arc being hot, moves up naturally along the horns. So it is elongated and naturally quenched.

2 marks for description

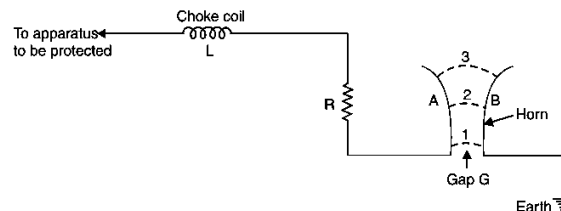

2 marks for diagram

4 a) iii) Describe arc extinction process in brief.

Ans:

Arc Extinction Process:

During fault condition, when the tripping mechanism operates the circuit breaker to open its contacts, arc is produced between the contacts. There are two methods of arc extinction:

- i) High resistance extinction method
- ii) Low resistance or Zero current extinction method

High resistance extinction method:

In this method, the arc is so controlled that its effective resistance increases with time so that the current reduces to a value insufficient to maintain the arc. The currents tends to be in phase with the voltage so that at zero current instant, the restriking voltage appearing across the contacts is relatively low and arc can not struck again. Arc path resistance is increased to reduce the current to low values while interrupting the arc.

2 marks

Arc resistance = v_{arc}/i_{arc} . The arc resistance mainly increased by:

- i) Lengthening of the arc by arc runners
- ii) Splitting the arc by arc splitters: An appreciable voltage is absorbed at the contact surface so that if the arc can be split into a number of small arcs in series, the voltage available for the actual arc column is reduced.
- iii) Arc cooling: The voltage required to maintain ionization increases with decrease of temperature of arc, so that cooling effectively increases the resistance.
- iv) Constraining the arc: If the arc can be constrained into a very narrow channel, the voltage necessary to maintain it is increased.

Current zero or Low Resistance Method:

This method is employed in a.c. circuit breakers since the ac passes through zero 100 times /second in 50 cycle current wave. When current wave passes through every zero, the arc vanishes for a brief moment. However the arc restrikes again with the rising

2 marks

Model Answers
Winter – 2018 Examinations
Subject & Code: Switchgear & Protection (17508)

current waves.

In this method, at current zero instant, fresh unionized medium is introduced between the space in between the contacts. Due to this medium deionization effect takes place. The dielectric strength of the contact space increases to such an extent that the arc does not continue after current zero.

- 4 a) iv) Explain distance protection of transmission line with neat sketch diagram.

Ans:

Distance protection of Transmission line:

Distance protection scheme uses impedance relay. The relay operation is based on the impedance (or distance) between the relay and point of fault. Figure shows arrangement for distance protection for typical transmission line.

2 mark for description

The voltage element of impedance relay receives supply from PT secondary and current element receives supply from CT secondary. It measures Impedance at relay location ($Z = V / I$)

The protection zone of line is between A and B under normal working conditions, the impedance of line is Z_L . The impedance relay is so designed that, it operates only when line impedance becomes less than Z_L .

When fault occurs between points A & B, the impedance of line becomes less than Z_L and impedance relay operates which operates the CB and line is protected.

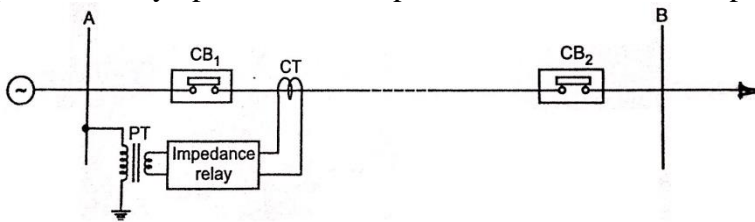

Distance protection scheme for typical transmission line

2 marks for sketch/ diagram

- 4 b) **Attempt any ONE of the following:**

06

- 4 b) i) Explain single phase phasing preventer with neat sketch diagram.

Ans:

Single phasing preventer:

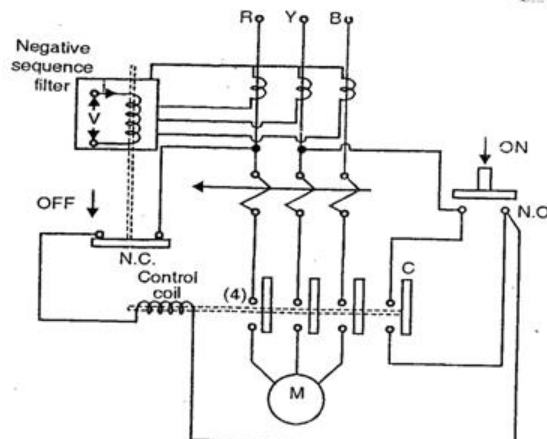

3 marks for diagram

Single phasing preventers are generally used for small / medium capacity motors.

Model Answers
Winter – 2018 Examinations
Subject & Code: Switchgear & Protection (17508)

Single phasing preventers are connected in secondaries of line CTs. These mainly contains a negative sequence filter. The output of negative sequence filter is fed to the level detector, which further sends tripping command to starter or CB.

When one of the three fuses blows off, two-phase supply is provided to motor. This is called “Single-phasing”. These two healthy phases get overloaded. The unbalanced condition causes negative sequence currents. The negative sequence currents cause reverse rotating magnetic field, leading to overheating of rotor and finally damage to the motor. Thus presence of negative sequence currents is considered as indication of single phasing condition. The negative sequence filter is used to detect the negative sequence current and so also the single-phasing. The output of negative sequence filter is fed to level detector which measures the negative sequence currents to ensure single-phasing. When the negative sequence currents cross the particular set level, the single-phasing is ensured and tripping command is given to circuit breaker or starter. Thus it protects motor from damage.

3 marks for explanation

4 b) ii) Explain fault bus protection scheme.

Ans:

Fault bus protection of busbar:

In this scheme, the substation is so designed that every fault on the bus bar is converted to earth fault. Under normal operating conditions, there is no current flowing through the fault bus to ground and the relay remains inoperative. When any fault occurs on busbar involving a connection between conductor and earthed support structure, it will cause a flow of current to earth through the fault bus. This results in operation of relay to actuate trip coil of CB to trip the circuit.

3 marks for explanation

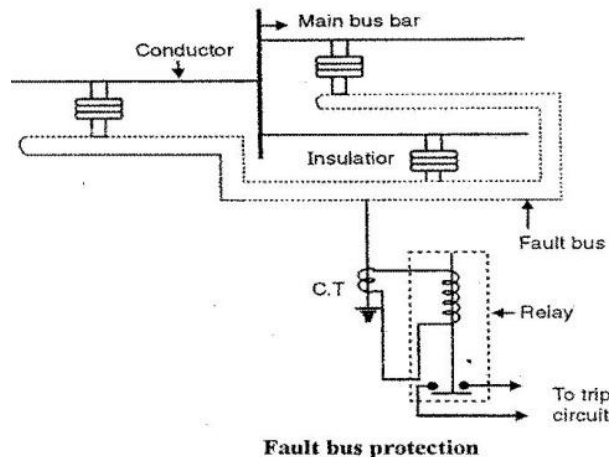

3 marks for diagram

5 Attempt any **FOUR** of the following:

16

5 a) Explain working of ELCB with neat sketch diagram.

Ans:

Earth Leakage Circuit Breaker(ELCB):

Earth leakage circuit breaker is a safety device used in electrical installations with high earth impedance to prevent shocks and disconnect power under earth fault conditions. It works on principle of relaying when the current in the earth path exceeds a set value. ELCB is used for protection against electric leakage in the circuit of 50 Hz or 60 Hz,

Model Answers

Winter – 2018 Examinations

Subject & Code: Switchgear & Protection (17508)

rated voltage single phase. 240 V, 3-ph. 440V. Rated current up to 60 Amp.
When the earth fault occurs, the ELCB cuts off the power within the time of 0.1 sec. automatically to protect personnel.

2 marks for explanation

Under normal conditions $(I_L - I_N) = I_f$ is very low or nearly zero. The CT surrounding the phase and neutral senses the differential current under earth fault and actuates the CB to operate (open). The difference current I_f through fault path resistance R_e is the leakage to earth. If this value exceeds a preset value, then the CB opens. Normally it is around 35 mA for tripping in domestic installations with tripping time being as low as 25 msec.

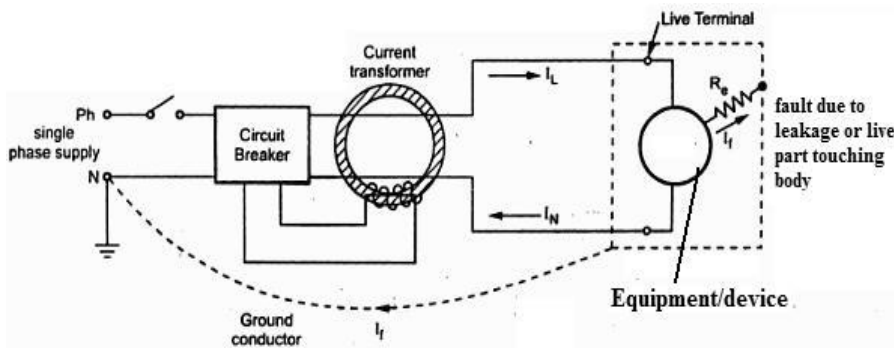

2 marks for diagram

5 b) Explain construction and characteristics of HRC fuse.

Ans:

Construction of H.R.C. Fuse: Figure shows the essential parts of a typical H.R.C. fuse. It mainly consist of a heat resisting ceramic body. Both the ends of the cermaic body consists of metal end caps. A silver current carrying element is welded to these metal end caps. The current carrying element is completely surrounded by the filling powder which may be plaster of parries, chalk, quartz or marble dust and acts as an arc quenching and cooling medium when fuse element blow off.

1 mark

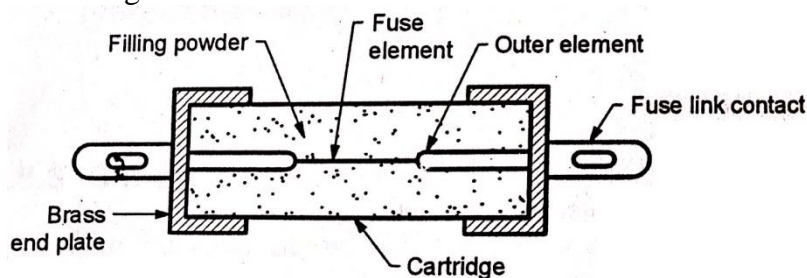

H.R.C. fuse

1 mark

Characteristics of HRC Fuse:

A Fuse operates when its element melts due to heat produced by $I^2 R_F$, where R_F is Fuse resistance. This heat produced increases if the current flowing through the Fuse element increases. Therefore, we can conclude that a Fuse element will melt faster for large fault current while it will take some time for lower value of fault current. This time-current relationship of Fuse is known as Characteristics of Fuse and is very useful for proper selection of Fuse for a particular circuit and for coordination purpose. A typical Fuse characteristic is shown in figure below.

1 mark



Model Answers
Winter – 2018 Examinations
Subject & Code: Switchgear & Protection (17508)

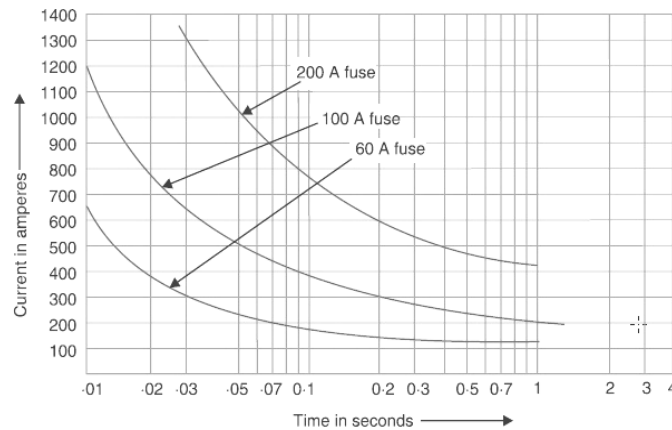

1 mark

- 5 c) Explain construction and operation of induction type directional over current relay.

Ans:

Directional overcurrent relay:

Construction:

It consists of two units:

- i) Non-directional Over-current unit
- ii) Directional power unit

The directional unit consists of upper electromagnet excited from potential transformer (PT), so it produces flux proportional to voltage. The lower electromagnet is excited from current transformer (CT), so it produces flux proportional to current. These two electromagnets are placed at the edge of aluminium disc. Eddy currents are produced in the disc and their interaction with the fluxes causes torque to rotate the disc. The coils on electromagnets are so placed that the torque is produced only for a particular direction of power flow. If the power flow is reversed, there will not be torque and so no rotation of the disc. The disc carries an arm to close the contacts when it rotates through some set angle.

The non-directional over-current unit also has upper and lower electromagnets. The upper electromagnet has two windings: primary is excited from CT as shown in the figure, and the secondary winding is connected to coil on lower electromagnet through contacts of directional unit, as shown in the figure. Thus when directional unit contacts remain open, the over-current unit remains unenergized.

Operation:

Under normal operating conditions, power flows in the normal direction in the circuit. For this direction of power flow, the directional power relay does not operate and overcurrent element remains unenergized.

However, when a short circuit occurs, and the current or the power flows in the reverse direction, the disc of the directional unit rotates to bridge the fixed contacts 1 & 2. This completes the circuit for over current element. The disc of this element rotates and moving contact attached to it closes the trip circuit. This operates circuit breaker which isolates the faulty section.

2 marks for explanation

Model Answers
Winter – 2018 Examinations
Subject & Code: Switchgear & Protection (17508)

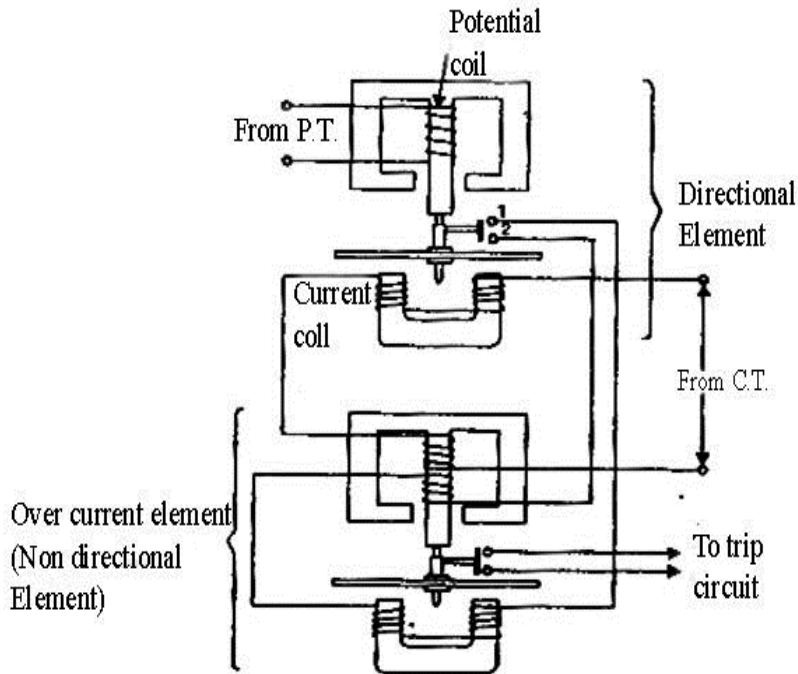

2 marks for diagram

5 d) Explain operation of μ P based relay with block diagram

Ans:

Operation of Microprocessor (μ P) based relay:

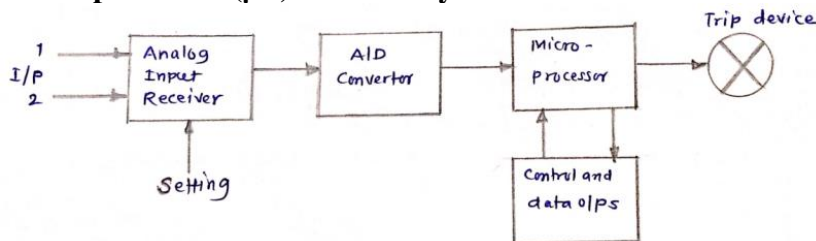

2 marks for block diagram

The inputs from the power system through CTs and PTS are received by the analog Input receiver; they are sampled simultaneously or sequentially at uniform time intervals. They are then converted into digital form through A/D converter and transferred to micro-processor. Digital signals are in the form of coded square pulses which represent discrete data. The signals are fed to micro-processor which is being set with the recommended values, compares the dynamic inputs and decides accordingly to generate trip/alarm signal to the output device.

2 marks for explanation

Or Equivalent Diagram And Description

5 e) Describe over current relay with time-current characteristic.

Ans:

Over current relay with time-current characteristics:-

1. Definite time over current relay: Operating time is constant, the relays operates after a predetermined time when the current exceeds the pickup value irrespective of the current magnitude. 1 mark
2. Instantaneous over current relay: The relay operates instantly when current exceeds pick-up value. No intentional time delay. 1 mark

Model Answers

Winter – 2018 Examinations

Subject & Code: Switchgear & Protection (17508)

3. Inverse time over current relay: The operating time depends on magnitude of operating current as shown in the figure. Higher the magnitude of current, lower is the operating time. The characteristic can be very inverse or extremely inverse as shown in the figure. 1 mark
4. Inverse definite minimum time overcurrent (I.D.M.T.) relay: Inverse time characteristics at lower value of fault current and definite time characteristics at higher values of fault current. 1 mark

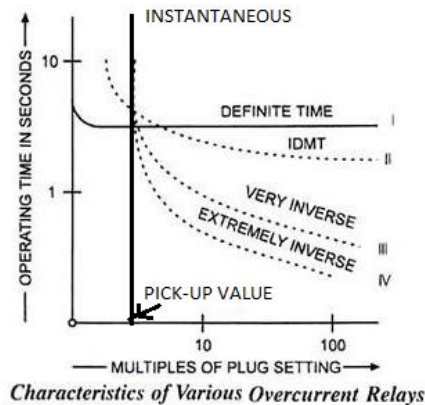

5 f) Explain MHO relay in detail.

Ans:

MHO Relay:

In this relay, poles 1, 2, 3 are energized by a voltage V through polarizing coil to produce flux, the capacitor connected provides phase shift. The left pole 4 is energized by a current which is the operating quantity.

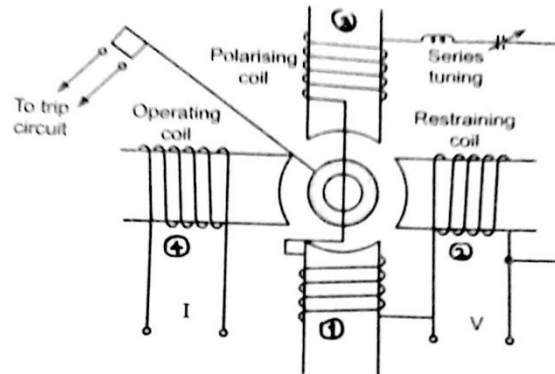

2 marks for Diagram

Here the rotor is hollow cylindrical type which turns around its axis. Inside the rotor stationary core is there. The

rotating field is produced by operating coil flux and polarized flux. This rotating field induces currents in the cup to provide necessary driving torque, which closes the trip contacts of CB.

2 marks for Description

The relay operation depends upon polarized flux because of voltage and operating flux because of current hence on the ratio $(I/V) = Y$ i.e. admittance, hence called as MHO relay.

OR Equivalent figure

6 Attempt any **FOUR** of the following:

16

6 a) Explain Buchholz relay with neat labelled diagram.

Ans:

Model Answers
Winter – 2018 Examinations
Subject & Code: Switchgear & Protection (17508)

Buchholz relay:

The relay is located in the path of the oil from transformer tank to conservator. As seen from diagram, the upper mercury switch operates the alarm circuit due to tilting of the float by accumulation of gas evolved slowly in the transformer tank due to minor faults which may develop into major ones if the alarm is not investigated.

Further lower mercury switch operates the trip circuit to switch off the circuit breaker related to the transformer when there is a sudden flow of oil from the transformer tank to conservator. Such flow occurs when there is serious fault in the transformer tank. Here the float (lower) is placed in such a manner that it senses the sudden violent movement of oil from transformer tank to conservator.

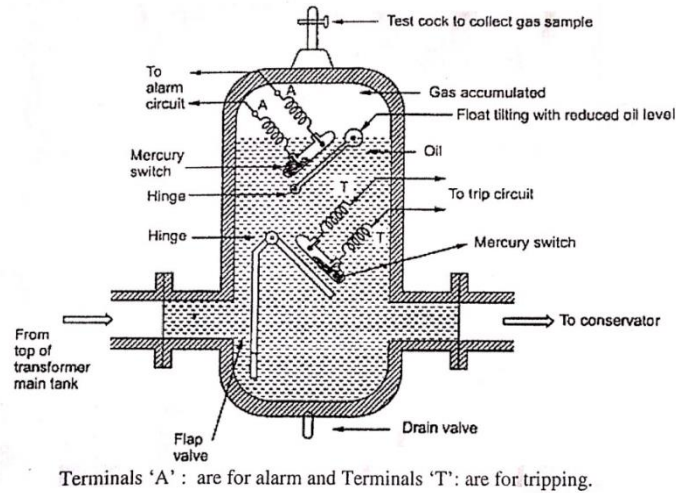

2 marks for explanation

2 marks for diagram

6 b) Explain operation of balanced beam type relay.

Ans:

Balanced Beam Type Relay:

Under normal operating condition the current through relay coil is such that the beam is held in the horizontal position by the spring. When the fault occurs on the system the current through relay coil increases and becomes greater than pick-up value and beam is attracted to close the trip circuit.

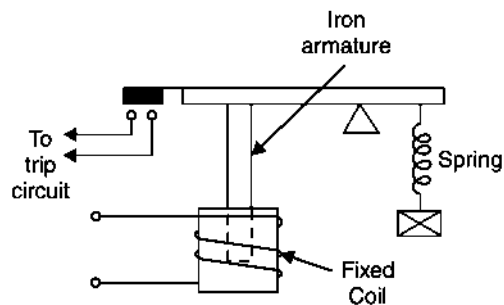

2 marks for diagram

2 marks for explanation

6 c) Explain negative phase sequence protection of alternator.

Ans:

Negative phase sequence protection of alternator:

Unbalanced loading on alternator mainly causes the negative sequence currents which generate the negative sequence components of magnetic fields. These fields rotate in opposite direction of the main field and induce emfs of double frequency in rotor winding causing overheating.

Figure shows a scheme for protection against negative phase sequence currents. Three

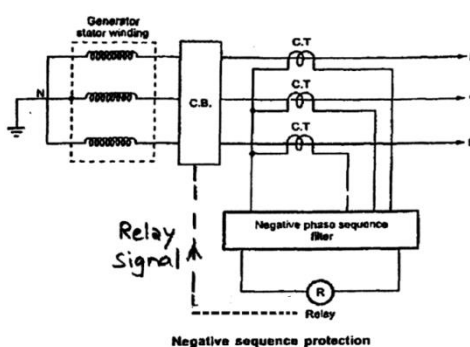

2 marks for explanation

2 marks for diagram

Model Answers
Winter – 2018 Examinations
Subject & Code: Switchgear & Protection (17508)

CT's are connected in star and the secondaries are connected to negative sequence filter. The relay is connected to sequence filter. The negative sequence filter consists of number of inductors and resistors. This negative sequence filter detects the presence of negative sequence components due to unbalance and operates the relay which further operates CB.

6 d) Explain over-current protection of transformer.

Ans:

Over-Current Protection of Transformer:

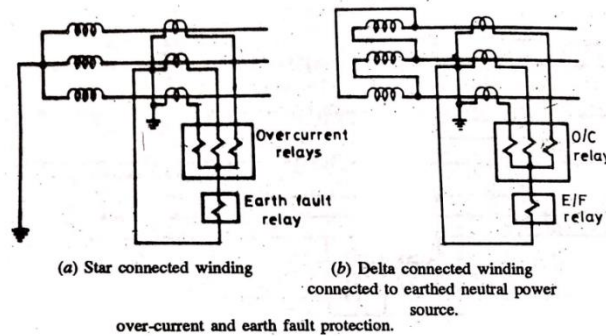

2 marks for diagram

Simple over-current & earth fault protection of transformer against external short-circuit and excessive overloads is shown in the above figure. The over-current and earth fault relays may be of inverse and definite minimum time type or definite time relays. The over-current relay has three elements; one for each phase winding. The normal range of current setting available on IDMT over-current relay is 50% to 200%. Due to excessive overload or any external fault, when over-current flows through the transformer winding, the corresponding phase CT supply the current to over-current relay. The relay depending upon its setting, sends trip command to the circuit breaker and the transformer is disconnected from load or fault.

2 marks for explanation

6 e) Explain differential protection of busbar.

Ans:

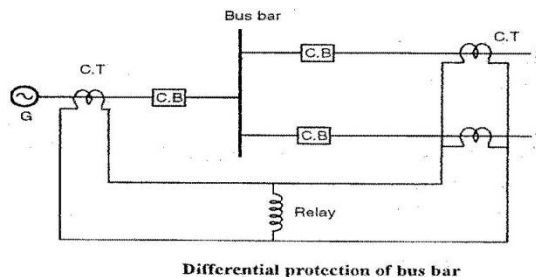

2 marks for diagram

Differential protection Scheme for bus bar:

Under normal conditions the sum of the currents entering the bus bar zone is equal to those leaving it and no current flows through the relay coil. If a fault occurs within the protected zone, the currents entering the bus will no longer be equal those leaving it. The difference of these currents will flow through the relay coil causing opening of circuit breaker.

2 marks for explanation