



WINTER- 18 EXAMINATION

Subject Name: **Advanced manufacturing processes** Model Answer Subject Code:

Important Instructions to examiners:

- 1) The answers should be examined by key words and not as word-to-word as given in the model answer scheme.
- 2) The model answer and the answer written by candidate may vary but the examiner may try to assess the understanding level of the candidate.
- 3) The language errors such as grammatical, spelling errors should not be given more Importance (Not applicable for subject English and Communication Skills).
- 4) While assessing figures, examiner may give credit for principal components indicated in the figure. The figures drawn by candidate and model answer may vary. The examiner may give credit for any equivalent figure drawn.
- 5) Credits may be given step wise for numerical problems. In some cases, the assumed constant values may vary and there may be some difference in the candidate's answers and model answer.
- 6) In case of some questions credit may be given by judgement on part of examiner of relevant answer based on candidate's understanding.
- 7) For programming language papers, credit may be given to any other program based on equivalent concept.

Q. No.	Sub Q. N.	Answer	Marking Scheme
1. a	i)	Four examples where traditional manufacturing can't be used and task is completed by non-traditional manufacturing process.(Any four) 1. Manufacturing of stent required in biomedical field by photochemical machining 2. Manufacturing of intraocular lenses by diamond turning process 3. Identification marking on automobile components by laser machining 4. Surface finishing on bio-implant joints by magneto-rheological grinding 5. Injector and nozzle holes by laser machining in hard materials 6. Manufacturing of ornaments by laser micromachining processes	1m for each example
	ii)	Advantages of CNC. (at least 6 advantages required for 4 marks) 1. High accuracy 2. Lesser time for manufacturing 3. Less machining time 4. Low cost components for mass production 5. Same programming data can be used for repetitive jobs 6. Lower machining cost in mass production of components 7. High surface finish 8. Multiple tooling is possible with the help of ATC	4

iii) **List the basic parts of horizontal broaching machine and state their functions.**
(4m for any four parts)

1. Broach: It is a multipoint cutting tool used for machining purpose (external and internal)
2. Pulling head: It holds broach and required for pulling purpose for machining.
3. Tool support: It is used to support other side of broach.
4. Bed: It is used to carry and support other accessories of machine.
5. Adopter: It is used to support the workpiece in cutting operation.
6. Fixture: It is used to hold the workpiece if necessary in cutting operation.
7. Table: It is used for mounting of fixture and workpiece.

1m for each parts

iv) **Explain EDM with neat sketch.**

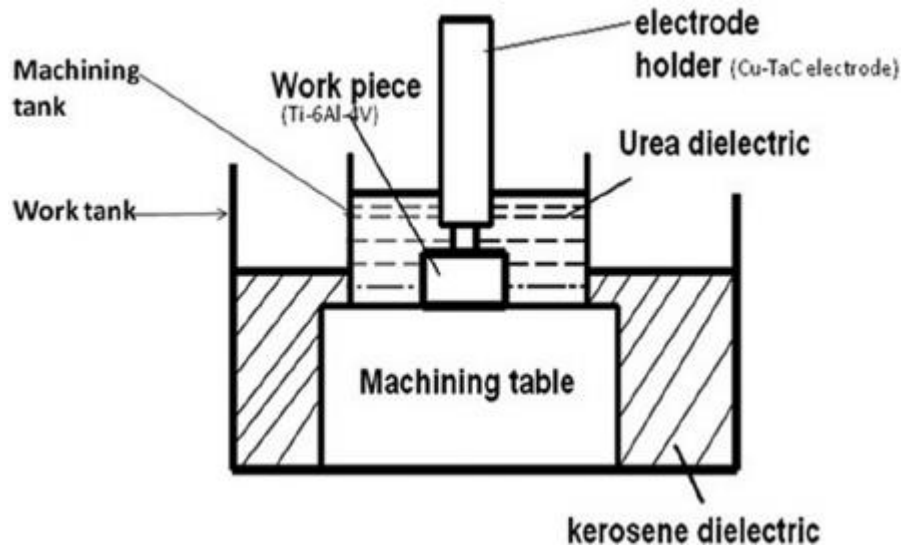

Fig. 2
marks and explanation
2 marks

In basic EDM process an electrical spark is created between an electrode and a workpiece. The spark is visible evidence of the flow of electricity. This electric spark produces intense heat with temperatures reaching 8000 to 12000 degrees Celsius, melting almost anything. The spark is very carefully controlled and localized so that it only affects the surface of the material. The EDM process usually does not affect the heat treat below the surface. With wire EDM the spark always takes place in the dielectric of deionized water. The conductivity of the water is carefully controlled making an excellent environment for the EDM process. The water acts as a coolant and flushes away the eroded metal particles.

<p>1 b</p>	<p>i) Explain plasma arc machining with neat sketch. State it's process parameters. (Fig. 2m, explanation 2m and process parameters 2m)</p> <div data-bbox="535 252 1088 756" data-label="Diagram"> </div> <p>The basic principle is that the arc formed between the electrode and the workpiece is constricted by a fine bore, copper nozzle. In the conventional system using a tungsten electrode, the plasma is inert, formed using either argon, argon-H₂ or nitrogen. This increases the temperature and velocity of the plasma emanating from the nozzle. The temperature of the plasma is in excess of 20000°C and the velocity can approach the speed of sound. When used for cutting, the plasma gas flow is increased so that the deeply penetrating plasma jet cuts through the material and molten material is removed in the efflux plasma.</p> <p>Process parameters of PAM:</p> <ul style="list-style-type: none"> • Current: Up to 500A • Voltage: 30-250V • Cutting speed: 0.1-7.5 m/min. • Plate thickness: Up to 200mm • Power require: 2 to 200 KW • Material removal rate: 150 cm³/min • Velocity of Plasma: 500m/sec 	<p>6</p>
<p>ii)</p>	<p>Describe open loop and closed loop control system. (3m for open loop and 3 m for closed loop)</p> <p>Open loop control system: Programmed instructions are fed into the controller through an input device. These instructions are then converted to electrical pulses (signals) by the controller and sent to the</p>	<p>6</p>

servo amplifier to energize the servo motors. The cumulative number of electrical pulses determines the distance each servo drive will move, and the pulse frequency determines the velocity. The primary drawback of the open-loop system is that there is no feedback system to check whether the program position and velocity has been achieved. If the system performance is affected by load, temperature, humidity, or lubrication then the actual output could deviate from the desired output. For these reasons, the open-loop system is generally used in point-to-point systems where the accuracy requirements are not critical.

Closed loop control system:

The closed-loop system has a feedback subsystem to monitor the actual output and correct any discrepancy from the programmed input. The feedback system could be either analog or digital. The analog systems measure the variation of physical variables such as position and velocity in terms of voltage levels. Digital systems monitor output variations by means of electrical pulses. Closed-loop systems are very powerful and accurate because they are capable of monitoring operating conditions through feedback subsystems and automatically compensating for any variations in real-time. Most modern closed-loop CNC systems are able to provide very close resolution of 0.0001 of an inch. Closed-looped systems would, naturally, require more control devices and circuitry in order for them to implement both position and velocity control. This, obviously, makes them more complex and more expensive than the open-loop system.

2. a) **Draw a neat sketch of abrasive jet machining and give it's two applications.**

(2m for sketch and 2m for applications)

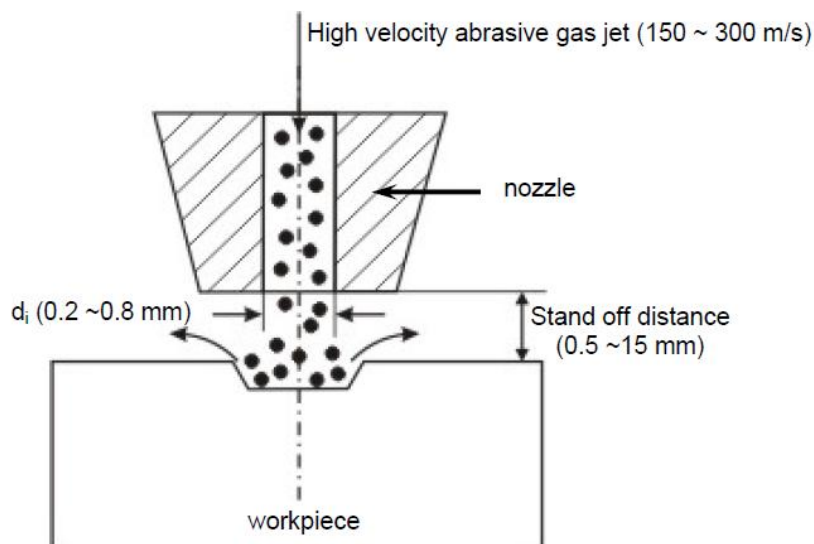

4

Applications:

- For drilling holes of intricate shapes in hard and brittle materials
- For machining fragile, brittle and heat sensitive materials
- AJM can be used for drilling, cutting, deburring, cleaning and etching
- Micro-machining of brittle materials

b) State the function of following codes in CNC programming

G01- Linear interpolation
G41- Cutter compensation left
M08- Flood Coolant On
M12- Shower Coolant On

c) Differentiate between up milling and down milling with neat sketch.

(any four points including sketch)

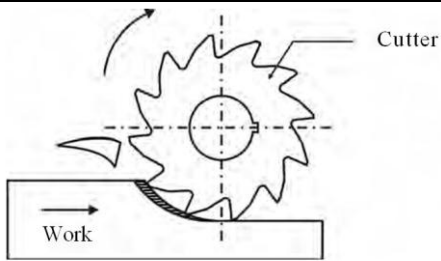
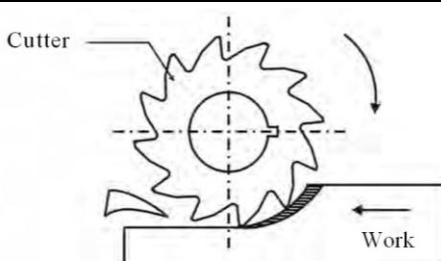
Sr. No.	Up milling	Down milling
1		
2	Workpiece fed in the opposite direction that of the cutter.	Workpiece fed in the same direction that of the cutter.
3	Chips are progressively thicker.	Chips are progressively thinner.
4	Strong clamping is required.	Strong clamping is not required.
5	Poor surface finish.	Good surface finish.
6	Used for machining of hard materials.	Used for machining of soft materials.

d) State different milling operations and draw a neat sketch of any one of it.

(2m for types of milling operations and 2m for sketch of anyone)

1. Plain/swab milling

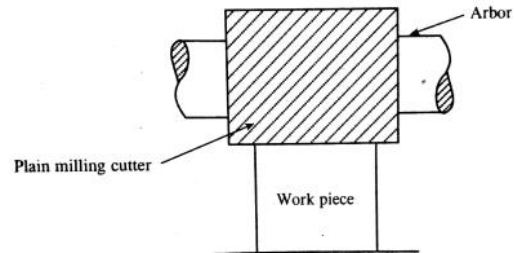

2. face milling

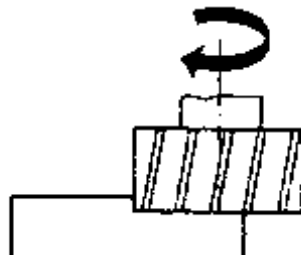

3. End milling



4. Side milling

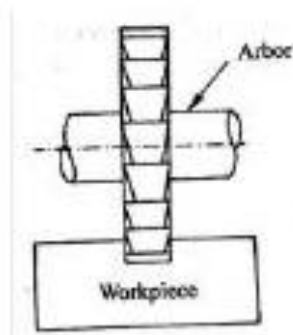

5. Angular milling

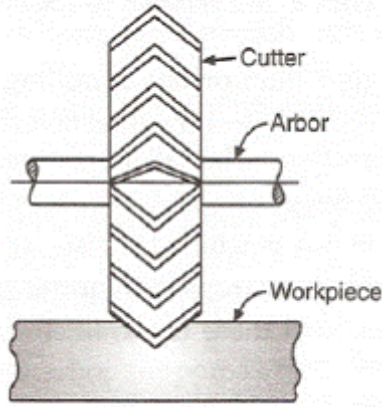

6. Form milling

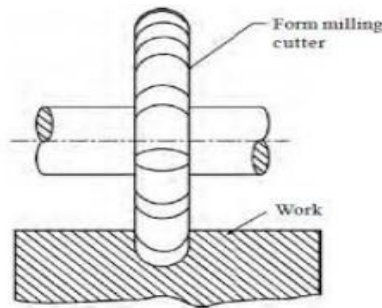

7. Straddle milling

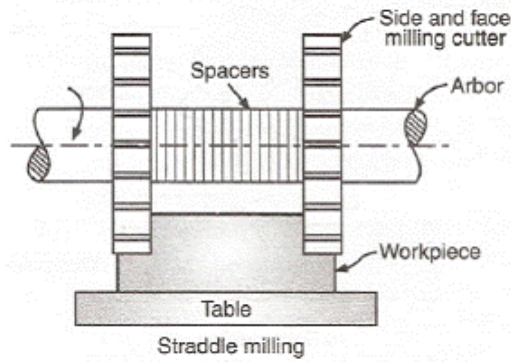

8. Gang milling

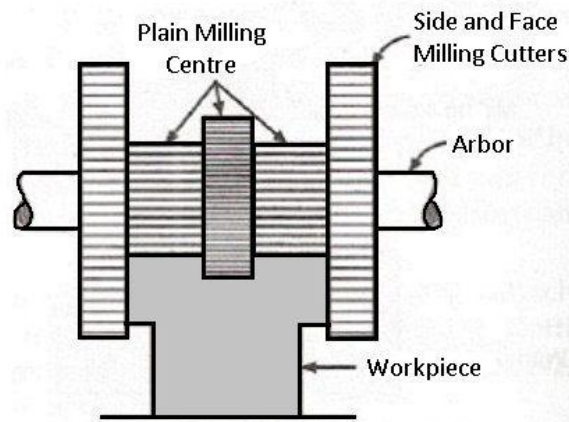



e) **State the classification of grinding machines.**

A. Rough grinding machines:

1. Hand grinding machine
2. Bench grinding machine
3. Floor stand grinding machine
4. Flexible shaft grinding machine
5. Swing frame grinding machine
6. Abrasive belt grinding machine

B. Precision grinding machines:

1. Cylindrical grinding machines
2. Internal grinding machines
3. Surface grinding machines
4. Tool and cutter grinding machines
5. Special grinding machines

4

3

a

(Figure and Coordinates 02 marks and Programme 06 Marks)

[Note: Meaning of codes is not compulsory]

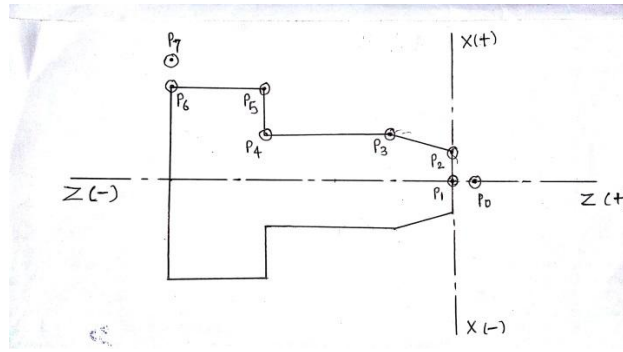

Figure No. 1

Point	X-Coordinate	Z-Coordinate
P0	0.0	5.0
P1	0.0	0.0
P2	30.0	0.0
P3	50.0	-20.0
P4	50.0	-70.0
P5	80.0	-70.0
P6	80.0	-110.0
P7	82.0	-110.0

2

PROGRAM

O1234;
 N001 G28 U0.0 W0.0;
 N002 G21G90G99G97;
 N003 M06T0101M08;
 N004 M03 S1500;
 N005 G00 X0.0 Z5.0;
 N006 G01 X0.0 Z0.0 F0.1;
 N007 G01 X30.0 Z0.0;
 N008 G01 X50.0 Z-20.0;
 N009 G01 X50.0 Z-70.0;

Program no.
Return to reference position
Input in mm, Absolute Programming,G99 for Feed in mm/rev&G97 for speed in rpm
Tool change tool no. tool offset no. coolant ON
Spindle Start clockwise with 1500 rpm
Move the tool rapidly to point P ₀
Move the tool linearly with Feed rate of 0.1mm/rev to point P ₁ (Touch point)
Move the tool with linearly Feed rate of 0.1mm/rev to point P ₂
Move the tool linearly with Feed rate of 0.1mm/rev to point P ₃
Move the tool linearly with Feed rate of

		0.1mm/rev to point P4	
N010	G01 X80.0 Z-70.0;	Move the tool linearly with Feed rate of 0.1mm/rev to point P5	06
N011	G01 X80.0 Z-110.0;	Move the tool linearly with Feed rate of 0.1mm/rev to point P6	
N012	G01 X82.0 Z-110.0;	Move the tool linearly with Feed rate of 0.1mm/rev to point P7(away from workpiece)	
N013	M09 M05;	Coolant STOP, Spindle STOP	
N014	G28 U0.0 W0.0;	Return to reference position	
N015	M30;	End of Program	

b
(Neat Labelled Sketch 02 Marks, Explanation 02 Marks, Advantages any two 02 Marks and Disadvantages any two 02 Marks)

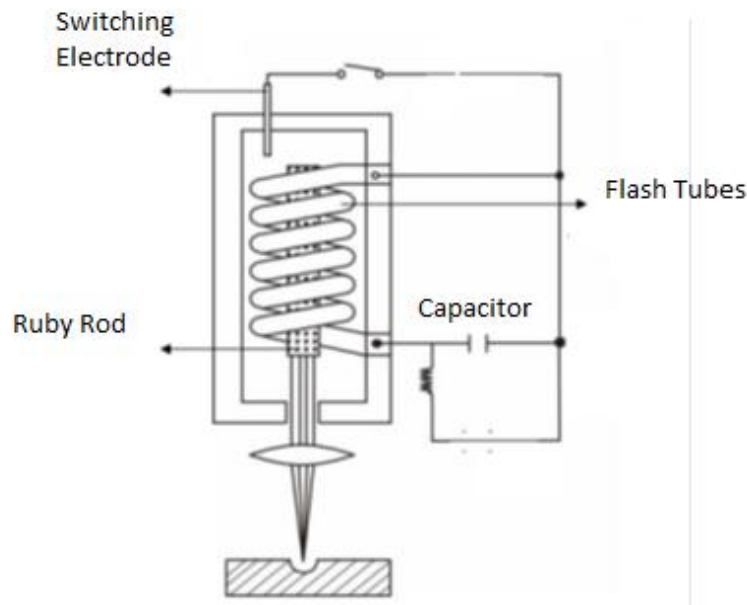

Fig: Laser Beam Machining

Laser beam machining (LBM) is an unconventional machining process in which a laser is directed towards the work piece for machining. Since the rays of a laser beam

02



aremonochromatic and parallel it can be focused to a very small diameter and can produce energy as high as 100 MW of energy for a square millimeter of area.

It consists of laser rod in the form of cylindrical crystal with 10 mm diameter and 150 mm long, its ends are well finished with close tolerances. It also has coil flash tube which is placed around ruby rod.

It is especially suited to making accurately placed holes. It can be used to perform precision micro-machining on all microelectronic substrates such as ceramic, silicon, diamond, and graphite.

Examples of microelectronic micro-machining include cutting, scribing & drilling all substrates, trimming any hybrid resistors, patterning displays of glass or plastic and trace cutting on semiconductor wafers and chips. A pulsed ruby laser is normally used for developing a high power.

Advantages

1. Good Surface finish with accurate profile can be obtained.
2. Extremely hard and brittle material can be easily machine.
3. Conducting as well as non - conducting material can be machined.
4. Any complicated shape can be produced.

Disadvantages:-

1. Its overall efficiency is extremely low
2. The process is limited to thin sheets
3. It has very low material removal rate
4. Cost is high

(List of Mfg. Methods 02 Marks, Sketch of any one and its Explanation 02 Mark each. Any two advantages 01 Mark and any two disadvantages 01 Mark)

[Note: Explanation of any other method with suitable sketch and its advantages and disadvantages can be considered]

I) based on the material removal process also called gear manufacturing with generating methods.

- 1) By the rotary wheel-milling with disc and end mill cutters.
- 2) By Rotating thread wheel-Gear hobbing.
- 3) By reciprocating /rotary tools like gear shaping with rack cutters & pinion cutters and with single point cutting tools.

02

02

02

02

II) With the forming

- 1) Cold Drawing
- 2) Gear Rolling.

III) With Casting

- 1) Die casting
- 2) Investment casting
- 3) Sand Casting.

IV) Gear making with the powder metallurgy

1. Gear milling;

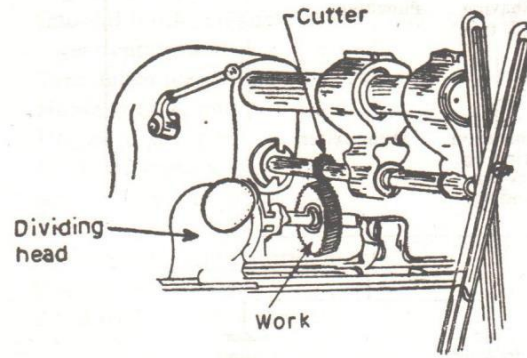

Fig: Gear milling with Form Cutter

Here a formed cutter is passed through the gear blank to effect tooth gap. Spur, helical, worm wheels and bevel gears can be manufactured by milling. Gear milling is less costlier and less accurate process. As the tooth depends upon the module, pressure angle and number of teeth, a series of cutters are selected for gear cutting. Each cutter cuts only limited range

Advantages :

- 1) Simple in construction.
- 2) Single cutter can be used for large range of gears
- 3) Suitable for batch production

Disadvantages:

- 1) Less Accurate
- 2) Time consuming
- 3) Not suitable for mass production
- 4) Skill requires
- 5) Extra attachment is required

OR

2. Gear Hobbing:

02

02

01

01

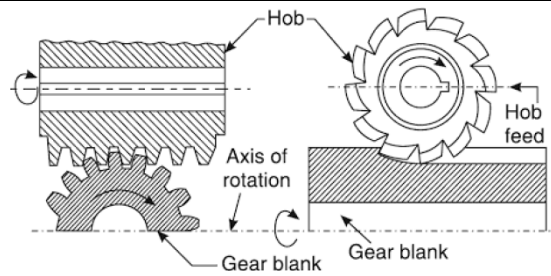

Fig: Gear Hobbing:

Gear hobbing is a continuous generating process in which the tooth flanks of constantly moving work piece are formed by equally spaced cutting edges of the hob. Every hob tooth, which contacts the gear along the line of action, produces one enveloping cut. Thus all enveloping cuts form a polygon of tangents to the involutes which on its corners forms a crest and deviates from the involutes curve.

The direction of feed of the hob can be achieved in three ways

Advantages;

1. Versatility, covers variety of gear types.
2. Indexing is continuous hence no error
3. High rate of production.

Disadvantages;

1. Not adopted to generate internal gears.
2. Restricted adjacent shoulders larger than root diameter of the gear.
3. Splines and serrations are not suitable for hobbing.

OR

3. Gear Shaping by Pinion Cutters:

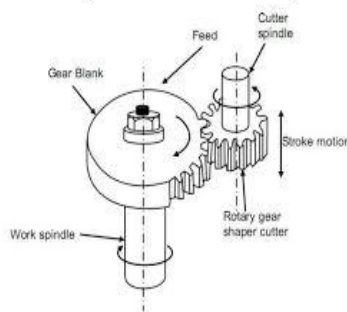

Fig: Gear Shaping by Pinion Cutters

In this method instead of rack cutter a pinion cutter having formed similar to gear to be produced is used. The pinion cutter reciprocates along vertical plane. Gear blank is mounted on a vertical shaft and rotates very slowly. The depth of cut is given during the cutting stroke (Downward stroke) and during return stroke work is relieved and cleared



4	<p>A i</p>	<p>from cutter. During the process the cutter is fed radially to the gear blank to obtain required tooth depth. The use of pinion makes the process continuous and rate of production is more.</p> <p>Advantages:-</p> <ol style="list-style-type: none"> 1. One cutter is needed to cut all gears of same pitch 2. Faster method of gear production 3. Both internal and external gears can be shaped <p>Disadvantages:-</p> <ol style="list-style-type: none"> 1. Frequent maintenance of cutter is required 2. Gear Finishing operation is necessary after this process <p><i>(Explanation 02 Marks Any Two Applications 02 Marks. Sketch is not Compulsory)</i></p> <p>Lapping: It is the process used for improving surface finish by reducing roughness, waviness & other irregularities on the surface. Material for lapping tool can be natural or artificial abrasives depending on workpiece material. Lubricant is used to hold or retain the abrasive grains during operation.</p> <p>Lapping operation is done two methods</p> <ol style="list-style-type: none"> 1) Hand lapping:- Workpiece is held in hand & the motion of the other enables the rubbing of two surfaces in contact. 2) Machine lapping:- It is done to obtain highly finished surfaces on workpiece. <p>Applications:-</p> <p>Press dies, Ball and roller bearings and engine parts like Piston rings, bearing races and cups, tappets and shafts, valve seats etc.</p>	<p>01</p> <p>01</p> <p>02</p> <p>02</p>
	<p>ii</p>	<p>WJM:</p> <p><i>(Any 4 Process Parameters 01 Mark each)</i></p> <p>Process Parameters:</p> <p>Material Removal Rate (MRR) / Accuracy / Surface Finishing:-</p> <p>With close control of various parameters a tolerance in the region of +/- 0.05 mm can be obtained. The MRR and Accuracy / Surface Finishing is depends upon</p> <p>[1] Diameter of Nozzle: -As the diameter increases pressure of the water decreases results into reduction of MRR and Accuracy</p> <p>[2] Jet Pressure: -As the jet pressure increases MRR increases and Accuracy decreases</p>	<p>01 for each</p>

[3] **Stand-off Distance (Distance of Work Piece from Jet):-**As the distance between jet and work-piece increases MRR decreases

[4] **Feed Rate:-** MRR decreases with increase in feed rate

[5] **Velocity of Fluid:-** MRR increases with increase in fluid velocity.

[6] **Flow Rate of Fluid:-** MRR increases with increase in fluid flow rate.

[7] **Viscosity of Fluid:-** MRR increases with increase in fluid Viscosity

[8] **Material of Nozzle:-** MRR varies as per nozzle material

iii

(Neat Labelled Sketch 02 Marks, Working /principle 02 Marks)

Buffing:

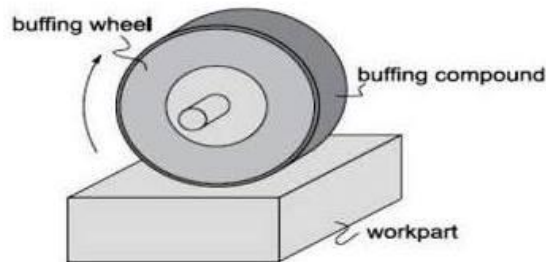

Buffing is a polishing operation in which the work piece is brought in contact with revolving cloth buffing wheel, that wheel usually has been charged with the fine abrasive. The polishing action in buffing is very closely related to lapping.

02

02

iv

(Any 4 Parameters 01 Mark each)

Maintenance Practices for Bearings:

(i) Never spin the bearing with compressed air.

(ii) Do not try to disassemble the bearing.

(iii) Avoid direct fire or fumes contact with bearing.

(iv) Do not hit the bearing with metal part/use bearing pullers while assembling or dismantling.

(v) Store the bearing away from moisture.

(vi) Check the clearance between bearing cap and bearing using plasti gauge before assembly.

01 for each

(vii) Do not run the bearing over its specified speed.

(viii) Do not throw away broken bearing, it may help you to know type of failure for corrective actions.

B i

(Figure 01 Mark each and Explanation 02 Mark each)

1. Gear Shaving Process:

Gear shaving process can be linear or rotary. In the linear type rack type cutter is used. While rotary method employs a pinion cutter. The cutter teeth are serrated to form a series of cutting edges. To obtain relative sliding action between the tooth profile the work gear and shaving cutter are set up in the gear shaving machine with cross axes. Due to the sliding action very small amount of material from the gear tooth is removed and finished profile surface is obtained.

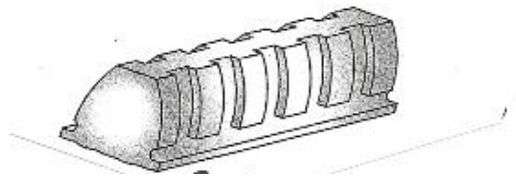

Fig: Gear shaving Tool with Serrations

2. Gear Grinding:

It is a finishing process to remove considerable amount of the metal after heat treatment to obtain predetermined quality gear. There are three general methods of gear grinding

- 1. Form wheel grinding
- 2. Generation grinding
- 3. Threaded wheel grinding

The grinding wheel is dressed to the form that is exactly required on the gear. Need of indexing makes the process slow and less accurate. The wheel or dressing has to be changed with change in module, pressure angle and even number of teeth. Form grinding may be used for finishing straight or single helical spur gears, straight toothed bevel gears as well as worm and worm wheels.

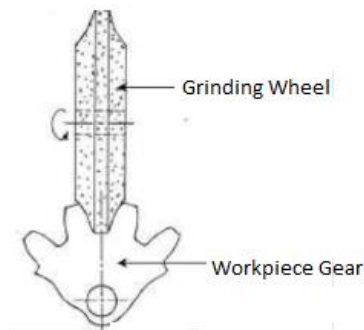



5	ii	<p><i>(Any six Precautions 01 Mark each)</i></p> <p>Precautions While Operating Grinding Machine:-</p> <ol style="list-style-type: none"> 1) Operator should always use safety devices such as goggles & aprons to protect his eyes and body from the flying abrasive particles and dust. 2) Wheel should be checked for the damage in the transit, cracks and other tests. Sound wheel when tapped lightly sound clear while crack wheel will not ring this is called ring test on grinding wheel. 3) Wheels not in used should be stored in dry place & placed on their edges in racks. 4) Wheel should be correctly mounted in the spindle and enclosed by the guards 5) Wheel speed which is dependent on bursting strength, grit size, bond, structure etc. and is usually specified by the manufacturers should not be exceeded in order to avoid the accidents. 6) Do not tighten the flange bolts excessively in order to avoid the cracking of the wheel. 7) During wet grinding the wheel should not be partly immersed in order to avoid out of balance of the wheel. 8) Ensure adequate power supply during grinding operation in adequate power may cause out of balance of the wheel 	01 for each
	a	<p>Basic maintenance practices for shaft</p> <ol style="list-style-type: none"> [1] Inspection of shaft for performance [2] Cleaning of shaft using [3] Oiling / Greasing / Lubrication of shaft [4] Inspection for performance after minor maintenance [5] Repair / Replacement of shaft if required [6] Inspection for performance of shaft after major maintenance 	4 Marks for explanation
	b	<p>honing process with its applications</p> <p>Principle:- Honing is a grinding or a abrading process mostly finishing round holes by means of bonded abrasive stones called hones. Materials ranged from plastics, silver, aluminium, brass and cast iron can be honed easily.</p> <p>Objectives:-</p> <ol style="list-style-type: none"> 1) To finish round holes 2) To correct some out of roundness 3) To remove tool marks and axial distortion 4) To finish taper parts 	1 Mark for principle 1 Mark for Diagram

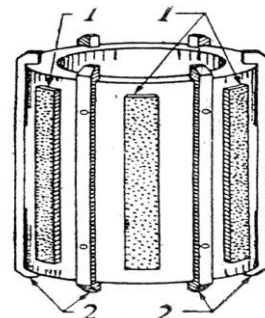

Set up: - Honing stones are made up of common abrasive and bonding materials. These are placed on the honing tool. The tool is placed on the mandrill and allowed to rotate and reciprocate. The work piece is held on the table. Honing stones may be loosely held in holders cemented into metal shells which are clamped into holders. Some stones are spaced at regular intervals around the holder while others are interlocking to provide continuous surface to the bore.

Working:-

Honing is cutting operation and has been used to remove as much as 3mm of stock. When the honing is done manually the tool is rotated and the work piece is passed back and forth over the tool. For precision honing the tool is given a slow reciprocating motion as it rotates.

Applications:-

- 1) Finishing automobile crankshafts journals
- 2) Finishing round holes

Finishing hollow cylindrical parts.

1 Mark for Description including set up and working

½ mark each for any 2 correct applications

c procedure for T slot milling

The operation of producing a key ways, grooves and slots of varying shapes and sizes can be performed. For T-slots a special type of cutter is used.

This operation perform in two steps,

[1] first by using an end mill plain slots are produced.

[2] In second stage, the T-slot cutter is used to enlarge and face the bottom of the slots

2 Marks for description

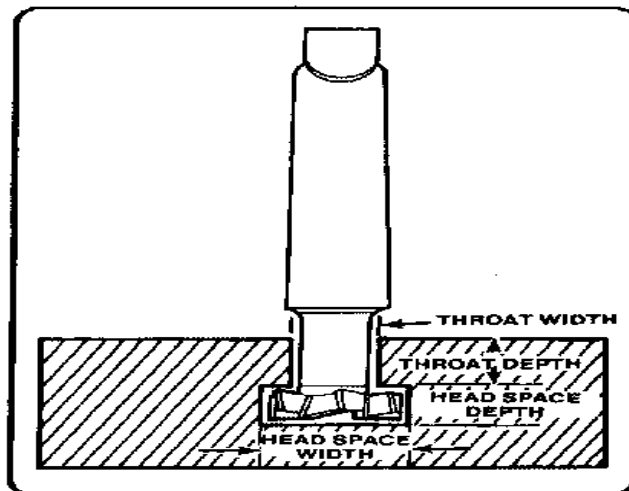

Figure 8-38. T-slot milling.

And

2 Marks for Diagram

d advantages, disadvantages and application of gear shaping process

Advantages:-

- 1) Only one cutter is needed to cut all gears of same pitch
- 2) Faster method of gear production

1/2 Mark

- 3) Both internal and external gears can be shaped
- 4) Set up time is less

Disadvantages:-

- 1) Frequent maintenance of cutter is required
- 2) Gear Finishing operation is necessary after this process
- 3) Requires frequent inspection of the tool for its wear

Applications:-

- 1) Cutting spur gears
- 2) Cutting herringbone gears
- 3) Ratchets gears
- 4) Splines

Gear segments

each for any 2 advantages

1/2 Mark each for any 2 advantages

1/2 Mark each for any 4 applications

e

two boring applications with neat sketch

Using boring machine following operations may generate

- [1] a flat surface,
- [2] produce cylindrical turned surface,
- [3] bore internal hole,
- [4] perform cutting off,
- [5] necking or forming operation
- [6] generate internal taper surface.

1 Mark each for description

and

It has horizontal revolving table for accommodating the work. In a vertical boring machine the workpiece rotates and tool has continuous linear feed motion. Stationary tool operates on revolving work.

1 mark each for its diagram

In boring the work remains stationary and the tool is rotated. Holes are bored by using boring bars. Multiple holes may be bored one after another by changing the position of the work piece and aligning it each time with the boring bar. To bore a hole the boring bar is fitted to the spindle and the cutter is adjusted in the boring bar to the required dimensions and a light cut is then taken.

for any 2 correct operations

[** Description for each operation involves above set up hence separately not expalined]

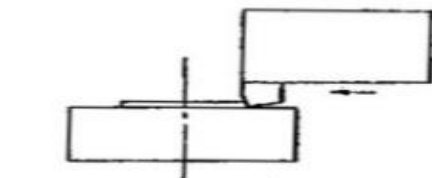

Machining flat surface

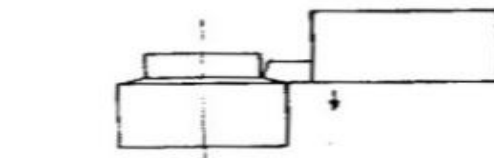

Turning cylindrical surface

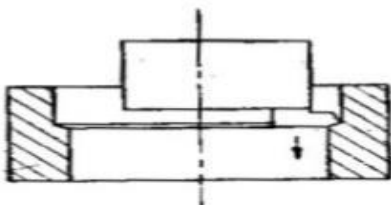

Boring by tool head

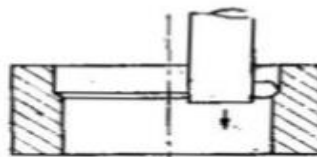

Boring by boring bar

f advantages and limitations broaching machines

Advantages:-

- 1) Rate of production is very high
- 2) Semiskilled operator can perform the operation
- 3) High accuracy
- 4) High surface finishing
- 5) Both roughing and finishing cuts are perform in one pass
- 6) The process can be used for internal and external surfaces

Limitations:-

- 1) High tool cost
- 2) Very large work pieces cannot be machined
- 3) The surfaces to be broach cannot have an obstruction
- 4) Large amount of stock (Material removal) cannot be removed

Work pieces must be rigidly supported

1 /2 Mark each for any 4 correct advantages

1 /2 Mark each for any 4 correct limitations

a indexing methods used in gear cutting. Describe any one

Methods of Indexing

- [1] Rapid or direct indexing
- [2] Simple or plain indexing
- [3] Compound indexing
- [4] Differential indexing
- [5] Angular indexing

[1] Rapid or Direct Indexing

It is the simplest method of indexing and is used only on work that requires a small number of divisions such as square, hexagonal etc.

In direct indexing the spindle is turned through a given angle without interposition of gearing. The dividing head has an indexing plate directly fitted on the spindle. The index plate has 24 holes. Crank may be rotated to divide the periphery of the work piece into the divisions 2,3,4,6,8,12, and 24. Since index plate is directly fastened to the spindle, one complete revolution of the index plate rotates the spindle also by one complete revolution.

Example: - If indexing is carried out for hexagonal head screw then
The number of holes to move in the index plate = $24 / N = 24/6 = 4$ Holes
N = required number of divisions to be made =6,

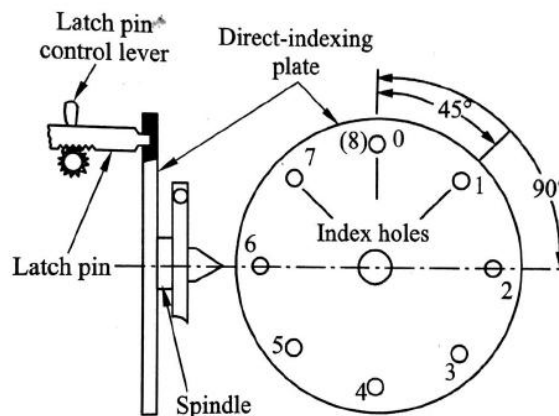

Fig. 11.35 Rapid or direct indexing

½ Mark each for any 4 correct methods

2 marks for description of any 1 method



[2] Simple or Plain Indexing

Plain indexing is used when it is required to divide a circle into more number of parts. Worm and worm wheel is used in between the index plate and the spindle. Index plate is not directly fastened to the spindle. Different index plates with varying number of hole circles may be used to increase range of indexing. Since the ration between worm and worm wheel is 1:40, 40 turns of index crank will revolve the spindle and job in one complete revolution.

To find the number of turns (T) of the index crank divide 40 by number of required divisions (N) of the periphery of the work piece.

$$T = 40 / N$$

If a number of divisions (N) required does not divide evenly into 40, the index crank must be moved a fraction part of a turn. This is done by another index plate with the dividing head

Each plate has six circles of holes as listed

Index plate 1:- 15,16,17,18,19,20

Index plate 2:- 21,23,27,29,31,33

Index plate 3:- 37,39,41,43,47,49

[3] Compound Indexing

- 1) Factories the number of divisions required.
- 2) Factories the standard number 40
- 3) Select for trial any two circles on the same plate and on its same side. Factories their difference
- 4) Factories the number of holes of one circle.
- 5) Factories the number of holes of the other circle.

capstan and turret lathes

b

Sr. No.	Capstan Lathes	Turret Lathes
1	The turret of capstan lathe is mounted on slides on the saddle	The turret of the turret lathe is directly mounted on bed
2	Less rigidity provided to the tool	More rigidity provided to the tool
3	Suitable for light weight bar works	Suitable for Larger and heavier loads
4	Handy for small components	Larger works can be machined easily
5	High production rate as fast cut is possible	High production rate can not be achieve easily as larger and heavier parts do not permit fast cut

1 Mark each for any 4 correct points

c

Repair Cycle Analysis

The repetitive performance of maintenance activities between two overhauling (inspection) is called as repair cycle analysis.

For maintenance planning repair cycle analysis is important.

3 Marks for



Need of repair cycle analysis:

- 1) It gives idea about staff required.
- 2) Number of small/minor repairs.
- 3) Number of major repairs.
- 4) Number of spare parts (quantity required for maintenance)

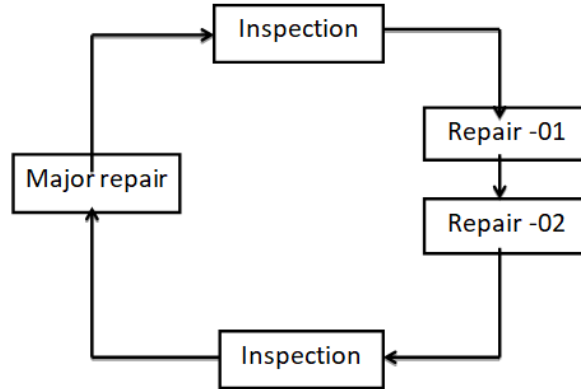

Repair cycle analysis involves:

[1] Primary Inspection:-

Proper examination of the machine tool is carried to identify the problem. In this stage root cause of the problem can be found out.

[2] Small Repair-01:-

In this stage as per the problem complexity cleaning or lubrication, type of small repair is performed.

[3] Small Repair-02:

After repair one if the problem still exists another small repairs like alignment, proper assembly, nut and bolt tightening is performed.

[4] Inspection:-

After small repair the machine tool is inspected for its performance.

[5]Major repair:-

If the small problem exists after small repair the major repair takes place like replacement of component or machining is required.

[6] Inspection:

After major repair the inspection carried out for effective and efficient performance of that machine tool.

description

and

1 Mark for diagram

d

single spindle automats

The general purpose single spindle automatic lathes are widely used for quantity or mass production (by machining) of high quality fasteners; bolts, screws, studs etc., bushings, pins, shafts, rollers, handles and similar small metallic parts from long bars or tubes of regular section and also often from separate small blanks.

[1] preferably and essentially used for larger volume of production i.e., large lot production and mass production used always for producing jobs of rod, tubular or ring type and of relatively smaller size.

[2] Single spindle automats run fully automatically, including bar feeding and tool indexing, and continuously over a long duration repeating the same machining cycle for each product

[3] provided with upto five radial tool slides which are moved by cams mounted on a cam shaft

4 Marks for description



	<p>[4] These are of relatively smaller size and power but have higher spindle speeds</p> <p>need of axis identification in CNC machines</p> <p>e [1] To obtain desired shape of the work piece it is necessary to move the spindle , slides in a different direction.</p> <p>[2] In part programming the requirement is to determine co-ordinates for given product as per drawing</p> <p>[3] It is essential to identify the machine axes to determine the co-ordinate as per the standardized system.</p> <p>[4] It is necessary for the part programming</p> <p>[5] Axis identification is required for the tool movement and coordinate selection</p>	<p>1 Mark each for any 4 correct points</p>
--	--	---