



WINTER- 18 EXAMINATION

Subject Name: Fluid Mechanics and Machinery Model Answer Subject Code:

17411

**Important Instructions to examiners:**

- 1) The answers should be examined by key words and not as word-to-word as given in the model answer scheme.
- 2) The model answer and the answer written by candidate may vary but the examiner may try to assess the understanding level of the candidate.
- 3) The language errors such as grammatical, spelling errors should not be given more Importance (Not applicable for subject English and Communication Skills).
- 4) While assessing figures, examiner may give credit for principal components indicated in the figure. The figures drawn by candidate and model answer may vary. The examiner may give credit for any equivalent figure drawn.
- 5) Credits may be given step wise for numerical problems. In some cases, the assumed constant values may vary and there may be some difference in the candidate's answers and model answer.
- 6) In case of some questions credit may be given by judgement on part of examiner of relevant answer based on candidate's understanding.
- 7) For programming language papers, credit may be given to any other program based on equivalent concept.

Q. No.	Sub Q. N.	Answer	Marking Scheme
1	A	Attempt any six of the following (2x6)	
	a	a) <b>Define density:</b> It is defined as mass per volume.	1
		<b>Specific gravity:</b> it is the ratio of mass density or specific weight of fluid to the mass density or specific weight of ideal fluid.	1
	b	b) <b>Define fluid pressure intensity:</b> it is force per unit area.	1
		<b>Pressure head:</b> It is the pressure exerted by a liquid and can also be expressed as the height of equivalent liquid column or vertical height or the free surface above any point in a liquid at rest.	1
	c	c) <b>State the Bernoulli's theorem</b>	
		Total energy per unit weight of an ideal fluid and incompressible fluid at any point during flow remains constant. Therefore	1
		Total energy per unit weight = $p/w + v^2/2g + Z = \text{constant}$	1
	d	d) <b>State the types of fluid flow</b>	
		1) steady and unsteady flow	
		2) uniform and non uniform flow	
		3) laminar and turbulent flow	
		4) compressible and incompressible flow	
		5) rotational and irrotational flow	2



WINTER – 18 EXAMINATION

Subject Name:

Model Answer

Subject Code:

17411

Q. No.	Sub Q. N.	Answer	Marking Scheme
	e	<b>Describe continuity equation</b> It is based on law of conservation of mass according to which the mass can neither be created nor destroyed. For a fluid flowing through a pipe of variable cross section, the quantity of fluid passing per second is constant at all sections. This is known as continuity equation. $Q = A_1 V_1 = A_2 V_2 = \text{constant}$	2
	f	<b>Define slip</b> It is the difference between theoretical discharge and actual discharge. <b>Negative slip:</b> Actual discharge of a reciprocating pump is more than the theoretical discharge. In such cases the coefficient of discharge will be more than unity, and the corresponding slip is known as negative slip of the pump.	1 1
	g	<b>Classify the hydraulic turbines</b> <b>According to the type of energy available at inlet to the turbine</b> 1) impulse turbine and 2) Reaction turbine <b>According to direction of flow through runner</b> 1) tangential flow turbine 2) radial flow turbine 3) axial flow turbine 4) mixed flow turbine <b>According to the head available at inlet to the turbine</b> 1) Low head turbine (2 m to 15 m)	2

2)Medium head turbine (16 m to 70 m)

3)High head turbine (71 m and above)

**According to the specific speed of the turbine**

1)low specific speed

2)medium specific speed

3)High specific speed

**h Explain the meaning of Impact of Jet**

the force exerted by the jet on a plate or vane which may be stationary or moving is called the impact of jet

The concept of impact of jet is used to determine forces alone or forces and work done.

**Attempt any TWO of the following(2x4)**

a) Enlist types of manometers and explain any one of them with neat sketch.

Types of manometers

A) simple manometer: 1) Piezometer

2) U- tube manometer

3) Micro-manometer

B) differential manometer: 1)U- tube differential manometers

2) Inverted U- tube differential manometers

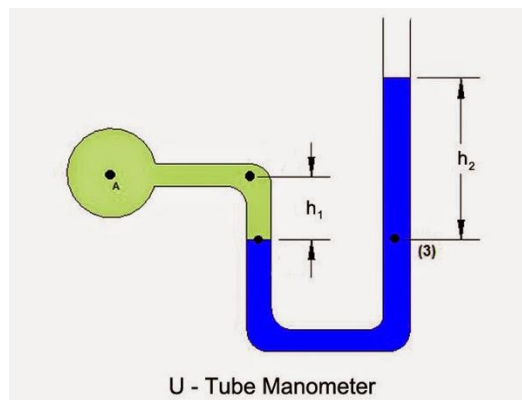

A manometer is a device used for measure the pressure of a fluid by balancing it with against a column of a liquid. Five different types of manometers are shown below with images.

U-Tube Manometer:

It consist of a U – shaped bend tube whose one end is attached to the gauge point 'A' and other end is open to the atmosphere. It can measure both positive and negative (suction) pressures. It contains liquid of specific gravity greater than that of a liquid of which the

2

1

Sketch -1

Explanation-  
2

( Any 1)

pressure is to be measured.

where 'γ' is Specific weight, 'P' is Pressure at A.

Pressure at A is  $P = \gamma_2 h_2 - \gamma_1 h_1$

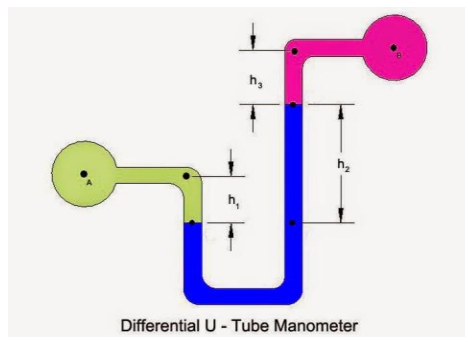

### Differential U-Tube Manometer:

A U-Tube manometric liquid is heavier than the liquid for which the pressure difference is to be measured and is not immiscible with it.

#### Construction

The simplest differential manometer is a U-shaped tube with both ends at the same height. A liquid, usually water or mercury, rests at the bottom of the tube.

#### Working

If one end of the tube is in a place with higher air pressure, the pressure will push down the liquid on that side of the tube. By measuring the difference between the heights of liquid, it is possible to calculate the difference in pressure.

Pressure difference between A and B is given by equation

$$P_A - P_B = \gamma_2 h_2 + \gamma_3 h_3 - \gamma_1 h_1$$

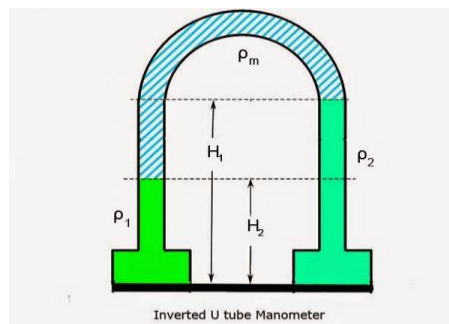

### Inverted U-Tube Manometer:

Inverted U-Tube manometer consists of an inverted U – Tube containing a light liquid. This is used to measure the differences of low pressures between two points where better accuracy is required. It generally consists of an air cock at top of manometric fluid type.

$$P_1 - \rho_1 * g * H_1 - \rho_m * g (H_2 - H_1) = P_2 - \rho_2 * g H_2$$

### Micro Manometer:

Micro Manometer is the modified form of a simple manometer whose one limb is made of larger cross sectional area. It measures very small pressure differences with high precision.

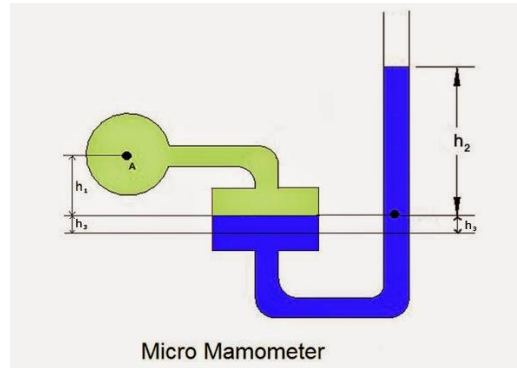

Let 'a' = area of the tube,  
A = area of the reservoir,  
 $h_3$  = Falling liquid level reservoir,  
 $h_2$  = Rise of the liquid in the tube,  
By conservation of mass we get  $A \cdot h_3 = a \cdot h_2$

Equating pressure heads at datum we get  
$$P_1 = (\rho_m - \rho_1) \cdot gh_3 + \rho_m \cdot gh_2 - \rho_1 \cdot gh_1$$

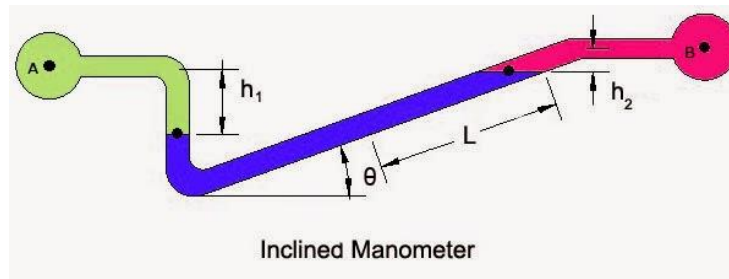

### Inclined Manometer

Inclined manometer is used for the measurement of small pressures and is to measure more accurately than the vertical tube type manometer. Due to inclination the distance moved by the fluid in manometer is more.

$$P_A - P_B = \gamma_2 l_2 \sin \theta + \gamma_3 h_3 - \gamma_1 h_1$$

b) Define atmospheric pressure, gauge pressure and absolute pressure. state relationship between them

**Atmospheric pressure:** The pressure exerted by the atmosphere on any surface in contact is called as atmospheric pressure.

1

1

**Gauge pressure:** The pressure which is measured above the atmosphere pressure is called gauge pressure.

1

**Absolute pressure:** Pressure which is measured above the absolute vacuum pressure is called the absolute pressure.

1

**Absolute pressure = Atmospheric pressure + Gauge pressure**

**$P_{abs} = P_{atm} + P_{gauge}$**

**C Explain Hydraulic Gradient Line and Total Energy Line**

**Hydraulic Gradient Line-** it is the sum of pressure head and datum head w.r.t. datum line.

1

Hydraulic Gradient Line lies below the total energy line by  $v^2/2g$

**Total energy line** - it is the sum of velocity head, pressure head and datum head w.r.t. datum line. Total energy Line lies above hydraulic gradient line by  $v^2/2g$

1

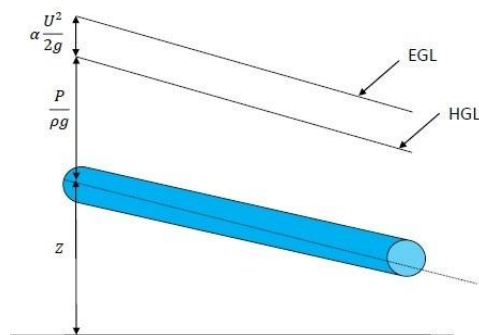

2

**Attempt any FOUR of the following (4x4)**

2

a

a) Explain Bourdon pressure gauge with a neat sketch

2

It is a device used for measuring the high pressure at a point in a fluid. This device give direct gauge pressure reading. They are portable. It is a stiff flattened metal tube bent into a circular shape. it consists of a bent tube of an elliptical cross section, a calibrated scale with pinion and gear arrangement. One end of tube A is sealed and its motion is transmitted to the pinion through the link E and gear. The other end B of tube is open through which the fluid pressure is transmitted to the tube. The Bourden gauge measures the pressure inside the tube and atmospheric pressure e. it measures the gauge pressure.

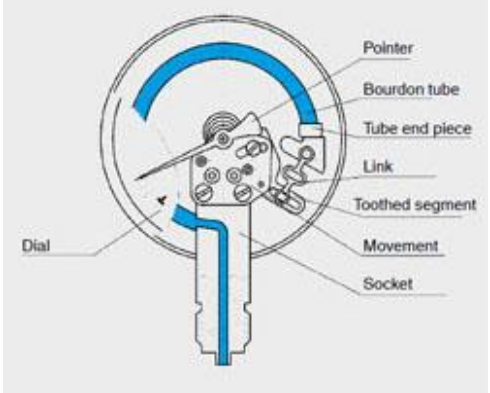

b

b) Explain with a neat sketch principle of working of orifice meter.

Orifice meter is a device used to determine the rate of flow through the pipe. It consists of a flat circular plate which has a sharp edged circular hole called orifice. It is fixed concentric to pipe. The orifice dia. is generally kept half of the dia. of the pipe. The value of  $C_d$  varies between 0.60 to 0.65. It is economical and less space is required for fitting. The liquid flowing from the orifice forms a jet whose area is less than the area of orifice at section 2-2 called vena-contracta. This vena-contracta occurs at a distance of half the dia. of orifice. At this section flow is laminar and parallel to each other and perpendicular to the plane of orifice. Then we define coefficient of contraction  $C_c$  as the ratio of area at vena-contracta to the area of orifice  $C_c = a_2/a_0$

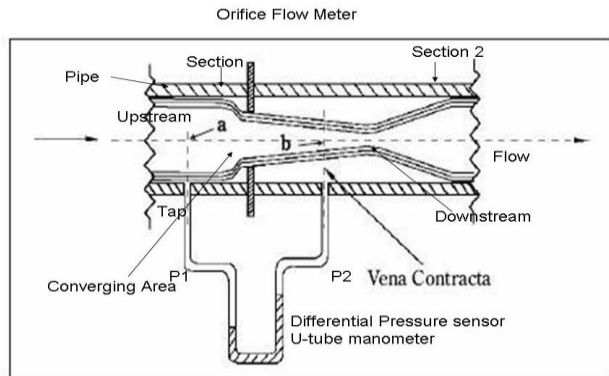

c

c) when plate is normal to jet area of jet,  $A = \pi / 4 D^2 = 0.7854 \times (0.095)^2 = 0.007088 \text{ m}^2$

$$m = \rho \times A \times V$$

$$= 1000 \times 0.007088 \times 25$$

$$= 177.21 \text{ kg/sec}$$

F = Rate of change of momentum =  $m (V - u) = 177.21 \times (25) = 4430.25 \text{ N}$

ii) when jet strikes the plate at  $30^\circ$

$$\text{Normal force on the plate} = m(V \sin \theta) = \rho \times A \times V \times V \sin \theta$$

$$= 177.21 \times 25 \times \sin 30^\circ = 2215.125 \text{ N}$$



d	<p>d) State the equation for hydraulic power transmission by fluid through pipe and obtain the condition for maximum power transmission</p> <p>Equation for hydraulic power transmission=weight of water per sec x Head at outlet</p> $P = (w \times \pi / 4 d^2 \times V) \times (H - fL V^2 / 2gd) \text{ watt}$ <p>the condition for maximum power transmission is obtained by differentiating equation w.r.t. V and equating the same to zero</p> $d(P)/dv=0$ $d/dV ( w \times \pi / 4 d^2 ( VH - fLV^3/2gd) ) = 0$ $w \times \pi / 4 d^2 ( H - 3 fLV^2/2gd) = 0$ $H = 3 fLV^2/2gd = 3 hf$ $hf = H/3$	1 1 1 1
e	<p>e) Explain Darcy's and Chezy's equation for frictional losses in flow through the pipes.</p> <p>Darcy's equation= <math>hf = 4 fLV^2/2gd = f L Q^2 / 3 \times d^5</math></p> <p>hf= loss of head due to friction</p> <p>L= length of pipe</p> <p>V= Velocity of flow</p> <p>d= diameter of pipe</p> <p>Q= discharge</p> <p>Chezy's equation=<math>hf = 4 V^2.L/C^2d, V = C \times (m \times i)^{0.5}</math></p> <p>Where, <math>i = hf/L</math> and <math>m = A/P</math></p> <p>hf= loss of head due to friction</p> <p>L= length of pipe</p> <p>V= Velocity of flow</p> <p>d= diameter of pipe</p> <p>C = Chezy's constant</p> <p>m= hydraulic mean depth</p>	1 1 1 1 1 1 1 1



f) Explain differential manometer with neat sketch

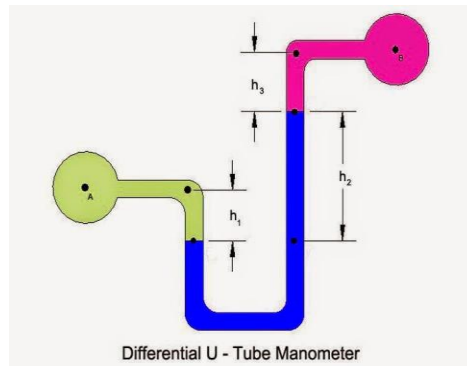

2

A differential manometer is a device that measures the difference in pressure between two places. Differential manometers can range from devices simple enough to be built at home to complex digital equipment.

#### Function

Standard manometers are used to measure the pressure in a container by comparing it to normal atmospheric pressure. Differential manometers are also used to compare the pressure of two different containers. They reveal both which container has greater pressure and how large the difference between the two is.

2

#### Use

Differential manometers have a wide range of uses in different disciplines. One example is that they can be used to measure the flow dynamics of a gas by comparing the pressure at different points in the pipe.

#### Construction

The simplest differential manometer is a U-shaped tube with both ends at the same height. A liquid, usually water or mercury, rests at the bottom of the tube.

#### Working

If one end of the tube is in a place with higher air pressure, the pressure will push down the liquid on that side of the tube. By measuring the difference between the heights of liquid, it is possible to calculate the difference in pressure. To calculate the difference in pressure, multiply the difference in height by the density of the gas and the acceleration due to gravity. The final units should be in Pascals.

3

a

**General layout of Hydroelectric Power Plant:**

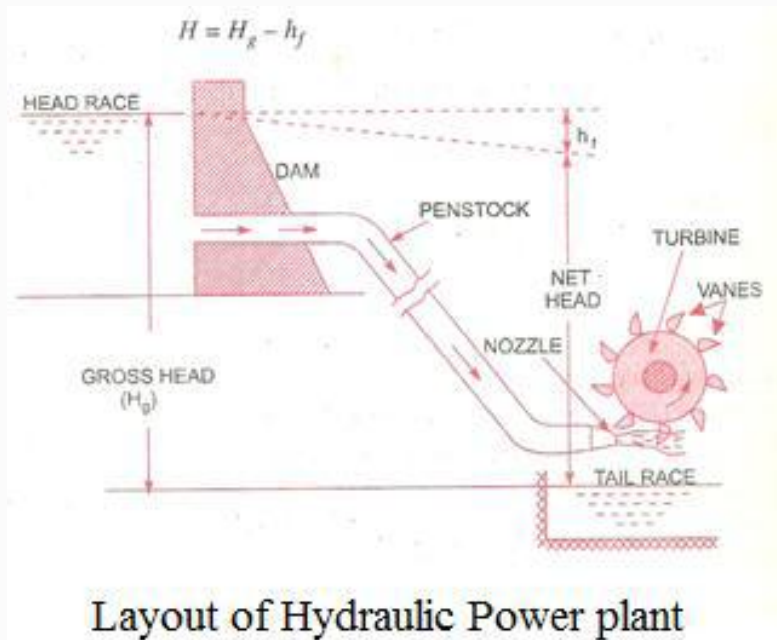

Figure –  
02 Marks

Explain –  
02 Marks

i) Dam (Reservoir):- It is water reservoir generally constructed over the river it contains lot of potential energy.

ii) Penstock: - Pipes of large diameters called penstock, which carries water under high pressure from storage reservoir to the turbines. These pipes are made of steel or reinforced concrete.

iii) Turbines:- These are the wheels on which number of vanes are fitted and converts hydraulic energy to mechanical energy.

iv) Tail race:- It is the channel which carries water away from turbines after the water has worked on turbines. The surface of water in the tail race is also known as tail race.

v) Surge tank:-It is the tank provided in the path of penstock to avoid pulsating discharge at inlet of turbines. During flow of water from reservoir to turbine through penstock pressure surges are created to compensate these surges surge tank is provided.

b

Given:

D=Diameter of Bucket=1m

Pressure at Nozzle (P) =15Bar =  $15 \times 10^5 \text{ N / m}^2$

Q=Discharge = $3.5 \text{ m}^3/\text{min} = 0.058 \text{ m}^3/\text{s}$

Turbine Speed N=600 RPM,

As the bucket is semi circular  $\Phi=0^\circ$

Let  $C_v=0.98, \eta_o=85\%$  (Student may solve problem using  $C_v=1$  &  $\eta_o=100\%$ )

Tangential Velocity  $u = \pi D N / 60$

$$=(3.14 \times 1 \times 600) / 60 = 31.41 \text{ m/s}$$

Head of Nozzle=(H)=(Pressure at the Nozzle)/(Specific weight of water) (as  $P=w.H$ )

$$=(15 \times 10^5) / (9810)$$

$$H = 152.91 \text{ m}$$

Velocity of Jet ( $V_1$ ) =  $C_v \times \sqrt{2 \times g \times H}$

$$\text{Velocity of Jet (V1)} = 0.98 \times \sqrt{2 \times 9.81 \times 152.91}$$

$$\text{Velocity of Jet (V1)} = 53.67 \text{ m/s}$$

1) Power Developed  $P = \eta_o \times W \times Q \times H$

$$= 0.85 \times 9810 \times 0.058 \times 152.91$$

$$= 73.95 \text{ Kw.}$$

2) Hydraulic efficiency  $\eta_h = \{ [2(V_1 - u)(1 + \cos \Theta) \times u] / [V_1^2] \}$

$$= \{ [2(53.67 - 31.41)(1 + \cos 0^\circ) \times 31.41] / [53.67^2] \}$$

$$\eta_h = 0.9709 = 97.09\%$$

Calculate  
u, H & V1  
– 01 Mark

each

Calculate  
Power –  
01 Mark

Calculate  
efficiency  
– 02  
Marks

Figure –  
02 Marks

c

**Kaplan Turbine:**

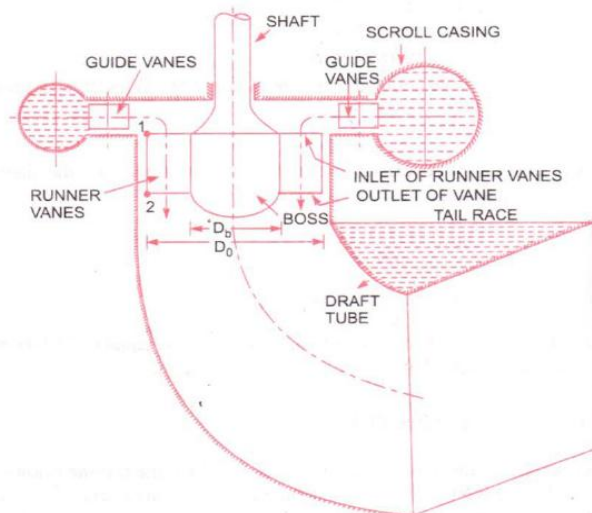

**or**

Explain –  
02 Marks

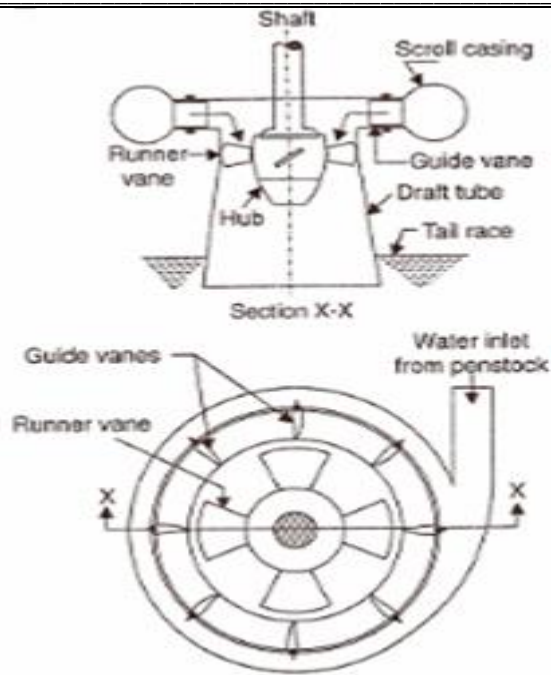

**Unique feature of Kaplan Turbine:** In Kaplan Turbine runner blades (small in numbers) are adjustable and can be rotated about pivot fixed to the boss of the runner.



d

Q3 d  
soln :

$\theta = 180 - 165^\circ = 15^\circ$

$H = 40 \text{ m}$

velocity of jet  $V = \sqrt{2g \cdot H}$

$$= \sqrt{2 \times 9.81 \times 40}$$
$$= 28.04 \text{ m/s}$$

Efficiency  $\eta = \frac{\text{Workdone}}{\text{K.E. of jet}}$

$$= \frac{\rho a v (v-u)(1+\cos\theta) \cdot u}{\frac{1}{2} \rho a v \cdot v^2}$$
$$= \frac{2(v-u)(1+\cos\theta) \cdot u}{v^2}$$

for maximum efficiency  $\frac{d\eta}{du} = 0$

$$\therefore \frac{d}{du} \left( \frac{2(v-u)(1+\cos\theta) \cdot u}{v^2} \right) = 0$$
$$\frac{2(1+\cos\theta)}{v^2} \frac{d}{du} (uv - u^2) = 0$$
$$\therefore v - 2u = 0$$
$$\therefore v = 2u$$

Calculate angle & V  
- 01 Mark

Calculate u - 01  
Mark

Calculate W - 02  
Marks

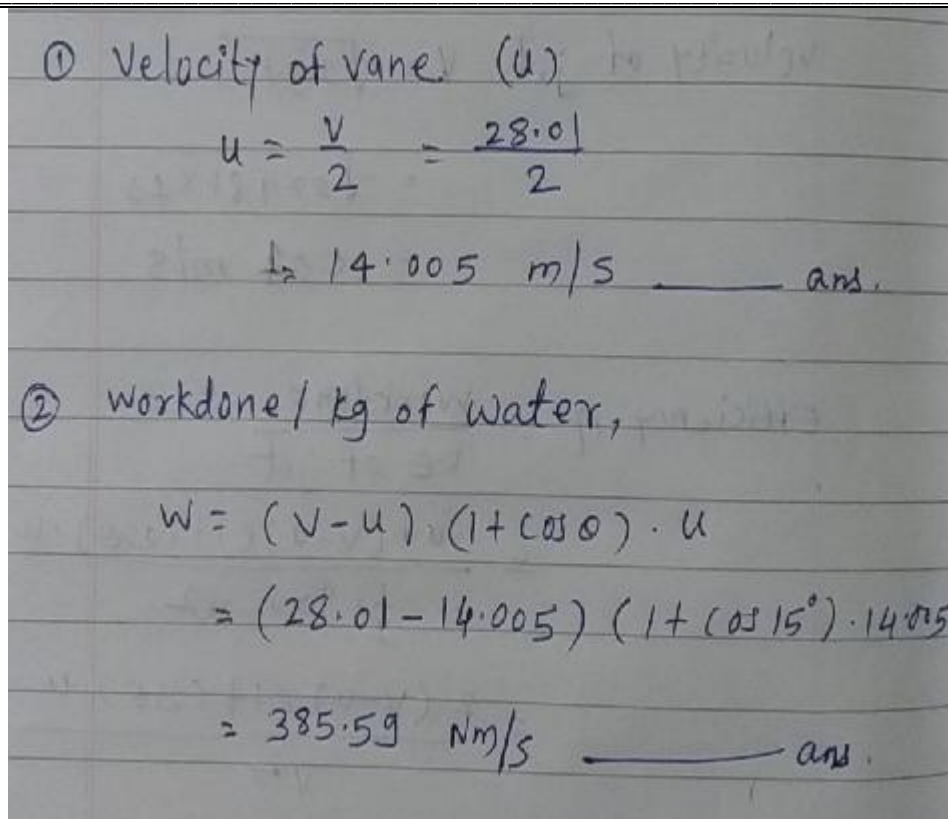

e **Surface tension:** Surface tension is defined as the force required to maintain unit length of the film in equilibrium condition.

Definition  
– 02 mark  
each

**Or**

It is the property of fluid which is defined as the tensile force acting on the surface of a liquid in contact with a gas or on the surface between two immiscible liquids such that the contact surface behaves like a membrane under tension.

**Capillarity** :- It is defined as a phenomenon of rise or fall of a liquid surface in a small tube relative to the adjacent general level of liquid when the tube is held vertically in the liquid. The rise of liquid surface is known as capillary rise while the fall of the liquid surface is known as capillary fall or depression

f

Q.3  
Soln:

$(AB) = \text{Diameter of plate} = 3 \text{ m}$   
 $(BC) = \text{Maximum depth} - \text{Minimum depth}$   
 $= 4 - 1.5 = 2.5 \text{ m}$

For  $\triangle ABC$ ,

$$\sin \theta = \frac{BC}{AB}$$

$$\therefore \theta = \sin^{-1} \left( \frac{BC}{AB} \right)$$

$$= \sin^{-1} \left( \frac{2.5}{3} \right)$$

$$\therefore \theta = 56.44^\circ$$

$\bar{x} = \text{Distance of point of C.G. from free surface}$   
 $= \frac{4 + 1.5}{2}$   
 $= 2.75 \text{ m}$

① Total pressure on plate  $P = W \cdot A \cdot \bar{x}$

$$= 9810 \times \frac{\pi (3)^2}{4} \times 2.75$$

$$= 190692.7 \text{ N}$$

$$= 190.7 \text{ KN} \quad \text{--- and.}$$

Calculate angle,  $\theta$  - 01 Mark

Calculate Total Pressure - 01 Mark

Calculate Position of center of Pressure - 02 Mark

② Position of center of pressure, ( $\bar{h}$ )

$$\bar{h} = \frac{I_g \sin^2 \theta}{A \bar{x}} + \bar{x}$$

$$I_g = \frac{\pi D^4}{64} = \frac{\pi (3)^4}{64} = 3.976 \text{ m}^4$$

$$A = \frac{\pi D^2}{4} = \frac{\pi (3)^2}{4} = 7.068 \text{ m}^2$$

$$\bar{h} = \frac{3.976 \times \sin^2(56.44)}{7.068 \times 2.75} + 2.75$$

$$= 0.14 + 2.75$$

$\bar{h} = 2.89 \text{ m}$  ————— ans.

4

a

**Attempt any TWO:**

**Draft Tube:** Draft tube is a pipe of gradually increasing diameter which connects the exit of runner of turbine to tail race.

**Types of draft tube:**

- i. Conical draft tube.
- ii. Simple elbow draft tube.
- iii. Moody spreading draft tube.
- iv. Elbow draft tube with circular cross section at inlet and rectangular at outlet.

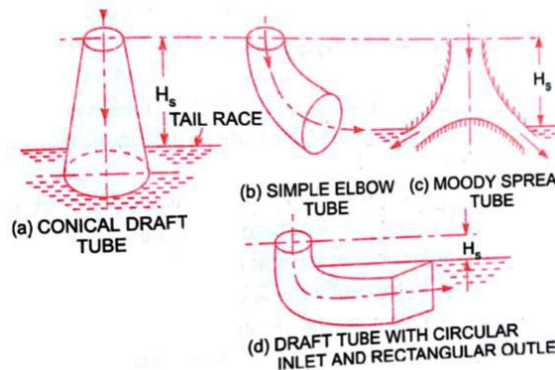

Definition  
– 02  
Marks

Types – 02  
Marks

Explain any  
one

(Figure – 02  
Marks &  
Explanation  
– 02 Marks)

**Conical Draft Tube: (Straight Divergent Tube)** The shape of this tube is that of frustum of a cone. It is usually employed for low specific speed, vertical shaft Francis turbine. The cone angle is restricted to 8° to avoid the losses due to separation. The tube must discharge sufficiently low under tail water level. The maximum efficiency of this type of draft tube is 90%.

**Simple Elbow Type** The draft tube is bent to keep its definite length. Simple elbow type draft tube will serve such a purpose. Its efficiency is, however, low (about 60%). This type of draft tube turns the water from the vertical to the horizontal direction with a minimum depth of excavation. The horizontal portion of the draft tube is generally inclined upwards to lead the





water gradually to the level of the tail race and to prevent entry of air from the exit end.  
**Elbow Draft Tube** It is circular in cross section at inlet in its vertical leg which turns into rectangular cross section in horizontal portion of tube at outlet. The horizontal portion of tube is gradually inclined upwards so that water leaves tube almost at tail race level. Efficiency of this tube is in range of 60 to 80%  
**Moody's Spreading Draft Tube:** This is a modification of conical tube and a solid conical cone is provided in the center of the tube with a flare at the bottom end. Such an arrangement allows a large exit area without excessive length. The solid core at the center enables full flow and reduces the eddy losses. The efficiency of the tube is about 85%.

4

b

Calculate  
 $u_2$  – 01  
Mark

Calculate  
 $V_{w2}$  – 01  
Mark

Q 4 b.

Given data:

- Outer diameter  $D_2 = 400 \text{ mm} = 0.4 \text{ m}$
- Width at outlet  $B_2 = 0.05 \text{ m}$  (500 mm)
- Speed  $N = 800 \text{ rpm}$
- Total head  $H_m = 15 \text{ m}$
- Vane angle  $\phi = 40^\circ$
- $\eta_m = 0.75$  (75%)

Tangential velocity at outlet  $u_2 = \frac{\pi \cdot D_2 \cdot N}{60}$

$$= \frac{\pi \times 0.4 \times 800}{60}$$
$$u_2 = 16.75 \text{ m/s}$$

$\eta_m = \frac{H_m}{\left(\frac{u_2 \cdot V_{w2}}{g}\right)}$

$$0.75 = \frac{15}{\left(\frac{16.75 \times V_{w2}}{9.81}\right)}$$

$\therefore V_{w2} = 11.71 \text{ m/s}$

$\tan \phi = \frac{V_{f2}}{u_2 - V_{w2}}$

$$\tan 40 = \frac{V_{f2}}{16.75 - 11.71}$$
$$V_{f2} = 4.22 \text{ m/s}$$

Calculate  
 $V_{f2}$  – 02  
Marks

Calculate  
 $V_2$  – 01  
Mark

Calculate  
angle – 01  
Marks



① Velocity of flow at outlet  
 $V_{f2} = 4.22 \text{ m/s}$  ————— ans.

② Velocity of water leaving the vane ( $V_2$ )  
$$V_2 = \sqrt{V_{w2}^2 + V_{f2}^2}$$
$$= \sqrt{(11.71)^2 + (4.22)^2}$$
$$= 12.44 \text{ m/s}$$
 ————— ans.

③ Angle made by absolute velocity at outlet with direction of motion ( $\beta$ )  
$$\tan \beta = \frac{V_{f2}}{V_{w2}}$$
$$= \frac{4.22}{11.71}$$
$$\beta = 19.81^\circ$$
 ————— ans.

④ Discharge ( $Q$ )  
$$Q = \pi \cdot D_2 \cdot B_2 \cdot V_{f2}$$
$$= \pi \times 0.4 \times 0.05 \times 4.22$$
$$\therefore Q = 0.265 \text{ m}^3/\text{s}$$
 ————— ans.

Calculate Discharge  
– 02 Marks

c

**Multistage Centrifugal Pump:-**

Multistage centrifugal pump has two or more identical impellers mounted on same or different shaft. These pumps are used to produce a high head, to discharge large quantity of liquid.

**1) Pumps in series (Centrifugal Pump for high head)**

For developing high head numbers of impellers are mounted in series on the same shaft which is shown in fig.

Definition  
– 02 Marks

Pumps in series (Diagram – 02 Marks, Explain – 01 Marks)

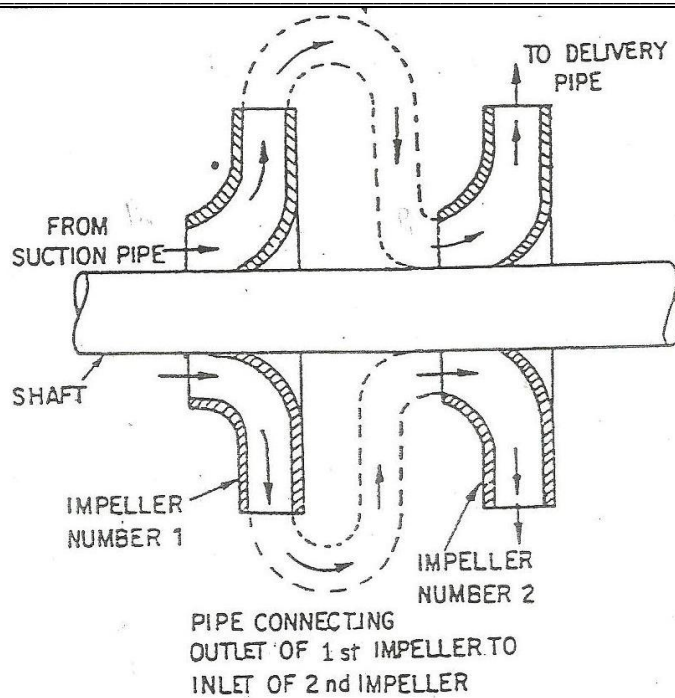

The water from the suction pipe enters the first impellers at inlet & it discharged at outlet with increased pressure. Then water with increased pressure from outlet of first impeller is taken by inlet of second impeller with the help of connecting pipe. At the outlet of second impeller pressure of water will be more than pressure of water at outlet of first impeller.

## 2 Pumps in Parallel (Centrifugal Pump for high discharge)

For obtaining high discharge at low head, pump should be connected in parallel shown in figure.

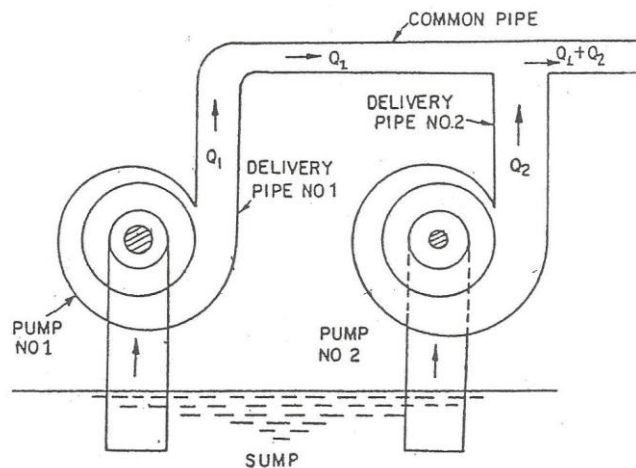

Here each pump lifts the water from same sump & discharges the water to common pipe. Each of pumps is working against same head.

Pumps in Parallel (Diagram – 02 Marks, Explain – 01 Marks)

5 Attempt any FOUR of the following

a Define for centrifugal pump

2 Marks

**NPSH:**

The net positive suction head (NPSH) is defined as the absolute pressure head at the inlet to the pump minus the vapor pressure head (in absolute head) plus the velocity head.

2 Marks

**Manometric efficiency:**

The ratio of the manometric head to the head imparted by the impeller to the water is known as manometric efficiency.

$$\eta_{\text{man}} = \text{manometric head} / \text{head imparted by impeller to water.}$$

b Enlist methods of priming of centrifugal pump

04

**Manually**

- In this method water is poured in the pump through funnel. When priming is being done, an air escapes through air vent valve.

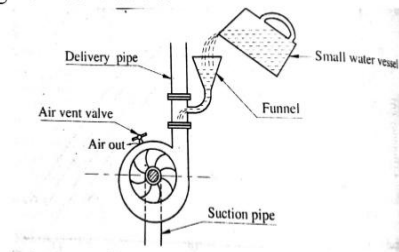

**With Vacuum Pump**

- In this method, the small size reciprocating pump is used priming the main centrifugal pump.
- The suction line of reciprocating pump is connected to the delivery line of main centrifugal pump.

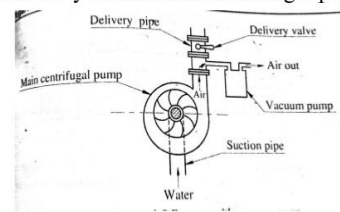

**With jet pump**

- In this method, water available at high head is allowed to flow through a nozzle.

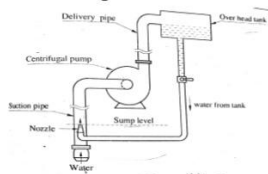

- The nozzle is so designed that at the jet outside the nozzle the pressure is less than the atm pressure so it is possible to suck water from the sump.

**With Seperator**

- In this method, air separator is provided on the delivery side of pump and bent suction pipe portion is provided at the inlet of the pump.
- Bent suction pipe portion always contain some liquid.
- The liquid heavier than air, so it falls back into separator and air moves in upward direction.
- Therefore the liquid and air are seperated in seperator.

(Enlist 1 Marks & Any two explanation)

c **Explain phenomenon of cavitation in reaction turbines**

Cavitation is defined as the phenomenon of formation of vapour bubbles of a flowing liquid.

Cavitation occurs when the pressure in any condition falls below the vapour pressure. While passing through hydraulic turbine water comes in a region where its pressure falls below vapour pressure. At this point vapour bubbles are formed. This can happen at the

04



outlet of the turbine, inlet of pump, bend of pipe or convex surface of curved vanes. The vapour bubbles travel along with the liquid and on reaching in region of high pressure, suddenly collapse creating a vacuum in the place. Collapsing of bubbles produce very high pressure which causes damage in the blades of runner and draft tube, etc. It causes small pits cavities to be formed on inside surface. This action is known as pitting. Cavitation reduces efficiency of turbine and hence it is not desirable.

d

Calculate the power transmitted by 250 mm diameter pipe of length 500 m carrying water under a head of 100 m. Take friction factor 0.0015

Given data  
d = diameter of pipe = 250 mm = 0.25 m  
L = Length of pipe = 500 m  
H = water head = 100 m  
f = friction factor = 0.0015  
p = power transmitted

$\therefore$  Loss of head  $h_f = \frac{fLV^2}{2gd}$  1 Mark

For maximum power transmission  
 $h_f = \frac{H}{3} = \frac{100}{3} = 33.33$  m  
 $h_f = 33.33$  m 1 Mark

$\therefore 33.33 = \frac{0.0015 \times 500 \times V^2}{2 \times 9.81 \times 0.25}$   
 $V^2 = \frac{163.48}{0.75} = 217.97 = 218$   
 $V = 14.76$  m/sec 1 Mark

$p = \rho g Q (H - h_f)$   
Rate of flow  $Q = \frac{\pi}{4} (0.25)^2 \times 14.76$   
 $Q = 0.724$  m<sup>3</sup>/sec 1 Mark

$p = 9810 \times 0.724 (100 - 33.33)$   
 $p = 473520$  watt = 473.52 kw.

04

e Explain construction and working of Venturimeter.

**Venturimeter:** A constructional detail of Venturimeter is as shown in the fig.

04

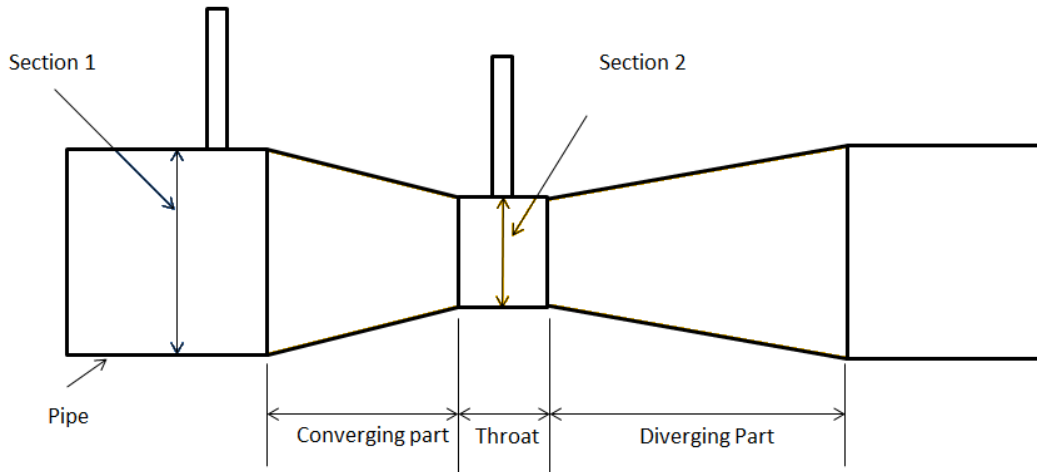

**Converging part:** It is that portion of the venturi where the fluid gets converges.

**Throat:** It is the portion that lies in between the converging and diverging part of the venturi. The cross section of the throat is much less than the cross section of the converging and diverging parts. As the fluid enters in the throat, its velocity increases and pressure decreases.

**Diverging part:** It is the portion of the venturimeter (venturi) where the fluid gets diverges.

**Working**

The venturimeter is used to measure the rate of flow of a fluid flowing through the pipes. Two cross section, first at the inlet and the second one is at the throat. The difference in the pressure heads of these two sections is used to calculate the rate of flow through venturimeter. As the water enters at the inlet section i.e. in the converging part it converges and reaches to the throat. The throat has the uniform cross section area and least cross section area in the venturimeter. As the water enters in the throat its velocity gets increases and due to increase in the velocity the pressure drops to the minimum. Now there is a pressure difference of the fluid at the two sections. At the section 1 (i.e. at the inlet) the pressure of the fluid is maximum and the velocity is minimum. And at the section 2 (at the throat) the velocity of the fluid is maximum and the pressure is minimum. The pressure difference at the two section can be seen in the manometer attached at both the section. This pressure difference is used to calculate the rate flow of a fluid flowing through a pipe.

(Construction 1.5, Working 1.5 & Sketch 1)

f **State law's of fluid friction for laminar flow.(any four)**

04

1. Frictional resistance is independent of pressure
2. Frictional resistance is proportional to velocity of fluid.
3. Frictional resistance is proportional to wetted surface area.
4. Frictional resistance is independent of nature of surface in contact.
5. Friction varies greatly with temperature.

6

A

Attempt any TWO the following

i)

- i) Derive an expression for force exerted by the jet on stationary incline flat plate in direction of jet.

04

Force exerted by the jet on stationary inclined flat plate

$\theta$  = inclined with direction of jet  
 $d$  = diameter of jet  
 $a$  = area of jet.  
 $v$  = velocity of jet flow.

Impulse momentum equation  
 Force in normal direction  
 $F_n = \frac{\text{mass}}{\text{sec}} [\text{velocity of jet before striking plate} - \text{velocity of jet after striking}]$   
 $= \rho a v [v \sin \theta - 0]$

$F_n = \rho a v^2 \sin \theta$  2 Marks

$F_x = F_n \sin \theta = \rho a v^2 \sin \theta \times \sin \theta$   
 $F_x = \rho a v^2 \sin^2 \theta$  (Horizontal)

$F_y = F_n \cos \theta = \rho a v^2 \sin \theta \cos \theta$  1 Marks  
 $F_y = \rho a v^2 \sin \theta \cos \theta$  (Vertical)



ii)

ii) Difference between Francis and Kaplan turbine (Any Four points)

04

Criteria	Francis	Kaplan
<b>According to type of flow</b>	Radial flow turbine but in case of modern Francis turbine water enters radially and leaves the turbine axially which is called as mixed flow turbine.	axial flow turbine i.e. water enters and leaves the turbine runner both in axial direction.
<b>Efficiency</b>	less as compare to Kaplan turbine	higher than Francis turbine
<b>Losses</b>	Friction losses are higher	Less friction losses as compare to Francis turbine
<b>Size</b>	The size of Francis turbine is quite large as compare to Kaplan turbine	Kaplan turbine compact in cross sectional area
<b>Vanes</b>	Large number of vanes in runner, generally the number of vanes are 16 to 24	Kaplan turbine is compact in size so the numbers of vanes are also less; the number of vanes is 4 to 8.
<b>Type of shaft</b>	The direction of shaft is may be vertical or horizontal as per requirement.	The direction of shaft is always in vertical direction because it is axial flow turbine.
<b>Head available</b>	Francis turbine requires medium range of water head i.e. it generally varies from 100-600 meters	Kaplan turbine works on very low head, the requirement of head is generally 100 meters.
<b>Flow rate</b>	it is works in medium head therefore it requires medium flow rate.	Kaplan turbine requires high flow rate of water.
<b>Specific speed</b>	Francis turbine works on medium range of specific speed i.e. the specific speed varies from 60 to 300.	Kaplan turbine requires high value of specific speed because it is works on low head. range of specific speed varies from 600-1000.
<b>Governing mechanism</b>	Fancies turbine has simple governing mechanism.	The governing mechanism of Kaplan turbine is quite complicated in construction and working.
<b>Runner vanes</b>	Francis turbine has fixed runner vanes on the shaft	Kaplan turbines vanes are adjustable.





b

A venturimeter is installed in a pipe line of 30 cm diameter, the difference pressure at entrance and throat ready by mercury manometer is 5 cm. when water flows at a rate of 0.05 m<sup>3</sup>/sec and if the discharge of coefficient of meter is 0.96, determine the diameter of throat.

Venturimeter

$$d_1 = 30 \text{ cm} = 0.3 \text{ m} \quad a_1 = \frac{\pi}{4} (0.3)^2 = 0.07 \text{ m}^2$$
$$x = \text{manometer Reading} = 5 \text{ cm} = 0.05 \text{ m}$$
$$Q = 0.05 \text{ m}^3/\text{sec}$$
$$C_d = 0.96$$
$$d_2 = ? \quad S_M = 13.6 \text{ (Hg)}$$
$$S_W = 1 \text{ (water)}$$
$$h = x \left[ \frac{S_M}{S_W} - 1 \right]$$
$$= 0.05 \left[ \frac{13.6}{1} - 1 \right] = 0.63$$
$$\boxed{h = 0.63 \text{ m}}$$

Rate of flow

$$Q = C_d \frac{a_1 a_2 \sqrt{2gh}}{\sqrt{a_1^2 - a_2^2}}$$
$$0.05 = 0.96 \frac{0.07 \times a_2 \sqrt{2 \times 9.81 \times 0.63}}{\sqrt{(0.07)^2 - a_2^2}}$$
$$0.05 = \frac{0.246 a_2 (0.96)}{\sqrt{(0.07)^2 - a_2^2}}$$
$$a_2 = 0.0243 \text{ m}^2$$

Diameter of throat  $d_2 = 0.175 \text{ m}$ .

$$\boxed{d_2 = 17.5 \text{ cm}}$$

08

C Explain construction and working of single acting reciprocating pump in with neat sketch.  
Draw an indicator diagram for its assuming air vessel both suction and discharge

### Single acting reciprocating pump:

- 1. Suction Pipe:** Suction pipe connects the source of liquid to the cylinder of the reciprocating pump. The liquid is suck by this pipe from the source to the cylinder.
- 2. Suction Valve:** Suction valve is non-return valve which means only one directional flow is possible in this type of valve. This is placed between suction pipe inlet and cylinder. During suction of liquid it is opened and during discharge it is closed.
- 3. Delivery Pipe:** Delivery pipe connects cylinder of pump to the outlet source. The liquid is delivered to desired outlet location through this pipe.
- 4. Delivery Valve:** Delivery valve also non-return valve placed between cylinder and delivery pipe outlet.
- 5. Cylinder:** A hollow cylinder made of steel alloy or cast iron. Arrangement of piston and piston rod is inside this cylinder. Suction and release of liquid is takes place in this so, both suction and delivery pipes along with valves are connected to this cylinder.
- 6. Piston and Piston Rod:** Piston is a solid type cylinder part which moves backward and forward inside the hollow cylinder to perform suction and deliverance of liquid. Piston rod helps the piston to its linear motion.
- 7. Crank and Connecting Rod:** Crank is a solid circular disc which is connected to power source like motor, engine etc. for its rotation. Connecting rod connects the crank to the piston as a result the rotational motion of crank gets converted into linear motion of the piston.
- 8. Strainer:** Strainer is provided at the end of suction pipe to prevent the entrance of solids from water source into the cylinder.
- 9. Air Vessel:** Air vessels are connected to both suction and delivery pipes to eliminate the frictional head and to give uniform discharge rate.

08

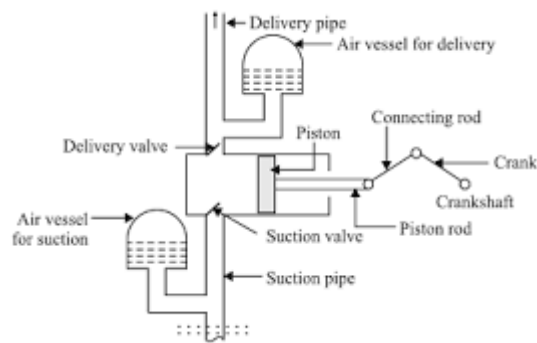

### Working of Reciprocating Pump

When the power source is connected to crank, the crank will start rotating and connecting rod also displaced along with crank.

The piston connected to the connecting rod will move in linear direction. If crank moves outwards then the piston moves towards its right and create vacuum in the cylinder.

This vacuum causes suction valve to open and liquid from the source is forcibly sucked by the suction pipe into the cylinder.

When the crank moves inwards or towards the cylinder, the piston will move towards its left and compresses the liquid in the cylinder.



Now, the pressure makes the delivery valve to open and liquid will discharge through delivery pipe.

When piston reaches its extreme left position whole liquid present in the cylinder is delivered through delivery valve.

Then again the crank rotate outwards and piston moves right to create suction and the whole process is repeated.

Generally the above process can be observed in a single acting reciprocating pump where there is only one delivery stroke per one revolution of crank. But when it comes to double acting reciprocating pump, there will be two delivery strokes per one revolution of crank.

indicator diagram for its assuming air vessel both suction and discharge

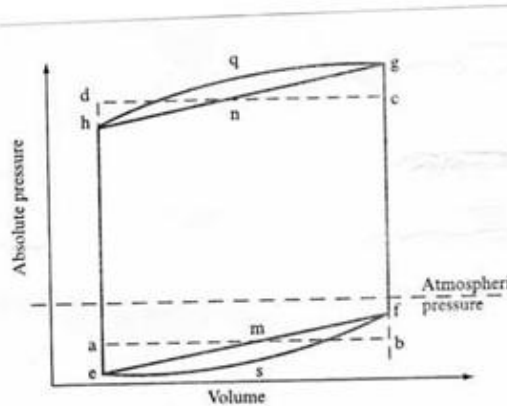

**Construction 2 Marks, Working 2 Marks , Sketch 2 Marks & Diagram 2 Marks)**  
2 Marks