



Diploma in Electrical Engineering: Winter – 2015 Examinations

Subject Code: 17508 (SAP)

Model Answers

Page No: 1 of 18

Important Instructions to examiners:

- 1) The answers should be examined by key words and not as word-to-word as given in the model answer scheme.
- 2) The model answer and the answer written by candidate may vary but the examiner may try to assess the understanding level of the candidate.
- 3) The language errors such as grammatical, spelling errors should not be given more importance (Not applicable for subject English and Communication Skills).
- 4) While assessing figures, examiner may give credit for principal components indicated in the figure. The figures drawn by candidate and model answer may vary. The examiner may give credit for any equivalent figure drawn.
- 5) Credits may be given step wise for numerical problems. In some cases, the assumed constant values may vary and there may be some difference in the candidate's answers and model answer.
- 6) In case of some questions credit may be given by judgement on part of examiner of relevant answer based on candidate's understanding.
- 7) For programming language papers, credit may be given to any other program based on equivalent concept.



Diploma in Electrical Engineering: Winter – 2015 Examinations

Subject Code: 17508 (SAP)

Model Answers

Page No: 2 of 18

1 (A) Attempt any THREE of the following:

3X4=12

1 (A) a) Draw the symbol and state the function of:

- i) Isolator
- ii) Circuit breaker
- iii) Earthing switch
- iv) Lightning Arrester

Ans:

Isolator :-

To disconnect the part of the system for maintenance from live circuit under no current condition.

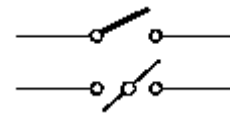

Circuit breaker:

To make or break a circuit manually or remotely under normal condition and to break circuit automatically under fault condition.

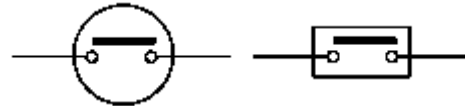

Earthing switch:

To discharge voltage on the line (due to charges of line capacitance) to earth after disconnecting line from live section.



Lightning arrester:

To divert the high voltage surges towards the earth, due to lightning or switching.

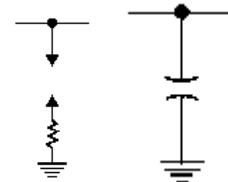

½ mark for each valid symbol
+
½ mark for each function
=
4 marks

1 (A) b) Write any eight causes of fault occurrence in the power System.

Ans:

Causes of Fault Occurrence in Power System:

- 1) Failure of insulation of components and equipment parts
- 2) Mechanical failure
- 3) Breaking of conductors.
- 4) Over temperature.
- 5) Lightning & switching surges.
- 6) Lines affected by birds ,objects , falling of trees
- 7) Harmonics produced in rotating machines.
- 8) Drawbacks in system design.
- 9) Lack of selection of good quality material.
- 10) Accidents
- 11) Excessive internal and external stresses.
- 12) Unbalanced currents.

½ mark for each cause

1 (A) c) Define the terms related to protective relay:

- i) Selectivity



Diploma in Electrical Engineering: Winter – 2015 Examinations

Subject Code: 17508 (SAP)

Model Answers

Page No: 3 of 18

- ii) Sensitivity
- iii) Reliability
- iv) Speed

Ans:

- i) **Selectivity:** It is the ability of protective system to select correctly that part of system in trouble and disconnect the faulty part without disturbing the rest of the system.
- ii) **Sensitivity:** It is the ability of the relay system to operate with low value of actuating quantity.
- iii) **Reliability:** It is the ability of the relay system to operate under predetermined conditions.
- iv) **Speed:** The relay system should disconnect the faulty section as fast as possible to prevent the electrical apparatus from damage and for system stability.

1 mark for each definition

1 (A) d) State the External and Internal causes of over-voltages.

Ans:

Causes of over voltages:

- a) Internal causes:
 - i) Switching surges
 - ii) Arcing ground
 - iii) Insulation failures
 - iv) Resonance
- b) External causes:
 - i) Direct Lightning strokes,
 - ii) Lightning discharge near the line
 - iii) Voltage induced due to change in atmospheric condition
 - iv) Voltage induced due to frictional effects of small particles such as dirt, dust snow.

2 marks for internal causes and

2 marks for external causes

1 (B) Attempt any ONE of the following:

1X6=6

- 1 (B) a) Two 11 kV, 3 ϕ , 3000 kVA generators having sub-transient reactance of 15% operate in parallel. Generators supply power to the transmission line through 6000 kVA transformer of ratio 11/22 kV and with a leakage reactance of 5%. Find fault current & fault MVA for 3-phase fault on
- i) H.T. Side
 - ii) L.T. side of transformer

Ans:

Assume base KVA = 6000 KVA

% Reactance related to base KVA

% X = (Base KVA / Rated KVA) x % Reactance on Rated KVA

$$X_{G1} = (6000/3000) \times 15\% \\ = 30\%$$

$$X_{G2} = 30\%$$

$$X_T = (6000/6000) \times 5$$



Diploma in Electrical Engineering: Winter – 2015 Examinations

Subject Code: 17508 (SAP)

Model Answers

Page No: 4 of 18

= 5 %

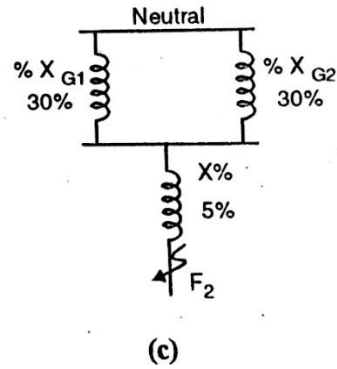
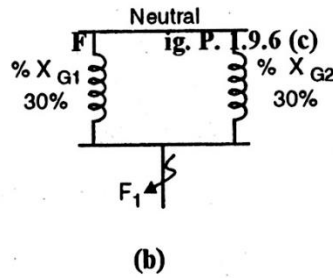
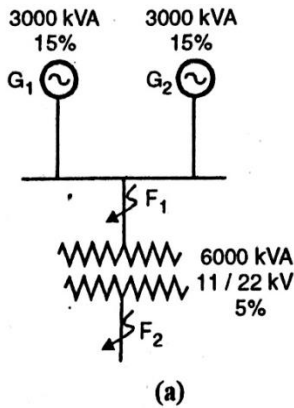

2 marks for figure

For Fault F1 (LT side)

Total reactance ,

$$\begin{aligned} \% X &= X_{G1} \parallel X_{G2} \\ &= 30 \parallel 30 \\ \% X &= 15\% \end{aligned}$$

$$\begin{aligned} \text{Rated current at base KVA} = I &= (6000 \times 1000) / (\sqrt{3} \times 11 \times 1000) \\ I &= 314.92 \text{ Amp} \end{aligned}$$

$$I_{SC} = I \times (100 / \% X) = 314.92 \times (100 / 15)$$

$$I_{SC} = \mathbf{2099.45 \text{ Amp}}$$

1 Mark

$$\begin{aligned} \text{S.C. KVA} &= \text{Base KVA} \times (100 / \% X) \\ &= 6000 \times (100 / 15) \\ &= 40000 \text{ KVA} \end{aligned}$$

$$\text{S.C MVA} = \mathbf{40 \text{ MVA}}$$

1 Mark

For Fault F2 (HT side)

$$\begin{aligned} \text{Total reactance is } \% X &= (X_{G1} \parallel X_{G2}) + X_T \\ &= 15 + 5 \end{aligned}$$

$$\% X = 20 \%$$

Rated current at base KVA

$$I = (6000 \times 1000) / (\sqrt{3} \times 22 \times 1000)$$

$$I = 157.45 \text{ Amp.}$$

$$\begin{aligned} I_{SC} &= I \times (100 / \% X) \\ &= 157.45 \times (100 / 20) \end{aligned}$$

$$I_{SC} = \mathbf{787.29 \text{ Amp}}$$

1 mark

$$\begin{aligned} \text{S.C. KVA} &= \text{Base KVA} \times (100 / \% X) \\ &= 6000 \times (100 / 20) \\ &= 30000 \text{ KVA} \end{aligned}$$

$$\text{S.C. MVA} = \mathbf{30 \text{ MVA}}$$

1 mark



Diploma in Electrical Engineering: Winter – 2015 Examinations

Subject Code: 17508 (SAP)

Model Answers

Page No: 5 of 18

- 1 (B) b) A three phase transformer having line voltage ratio of 0.4 kV/11kV is connected Star / Delta and protective transformers on the 0.4 KV side have a current ratio of 500/5. What must be ratio of the protective transformers on 11 kV Side? Draw a neat circuit diagram and indicate the given values at appropriate places.

Ans:

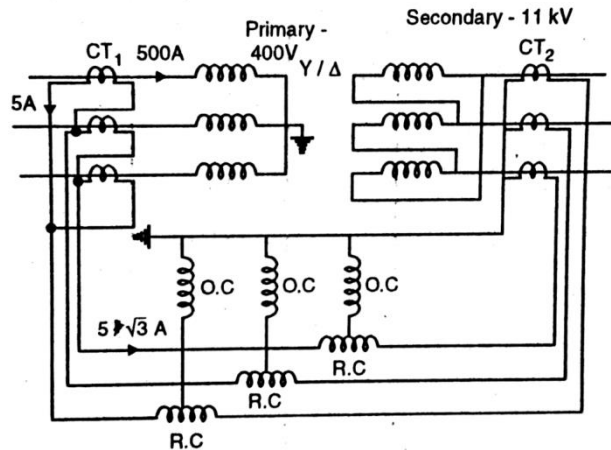

3 marks for diagram with values

- 1) Line current on 400 V side is 500 amp
Phase current on delta connected CT's on 400 V side = 5 amp
- 2) Line current of delta connected CT's on 400 V side = $5\sqrt{3}$ amp
- 3) Phase current of star connected CT on 11 KV side = $5\sqrt{3}$ amp
- 4) For transformer ,
 $\sqrt{3} V_1 I_1 = \sqrt{3} V_2 I_2$
 $\sqrt{3} \times 400 \times 500 = \sqrt{3} \times 11000 \times I_2$
 $I_2 = (\sqrt{3} \times 400 \times 500) / (\sqrt{3} \times 11000)$
 $I_2 = 200/11$

1 Mark

1 Mark

Therefore CT's Ratio on 11000 V side , = $(200/11) : (5\sqrt{3})$
= $200/(11 \times 5\sqrt{3})$
= $10.5 / 5$

CT ratio on 11 kV side = $10.5 : 5$

1 mark

2 Attempt any FOUR of the following:

4X4=16

- 2 a) Compare the fuse and MCCB on the basis of speed of operation, cost , construction and replacement strategy .

Ans:

Sr. No	Point	Fuse	MCCB
1	Speed	Operating time is very small (0.002 Sec or so)	Operating time is comparatively large (0.1 to 0.2 Sec)
2	Cost	Less	Comparatively more
3	Construction	Simple	Comparatively Complicated

1 mark for each point
= 4 marks



MAHARASHTRA STATE BOARD OF TECHNICAL EDUCATION
(Autonomous)
(ISO/IEC-27001-2005 Certified)

Diploma in Electrical Engineering: Winter – 2015 Examinations

Subject Code: 17508 (SAP)

Model Answers

Page No: 6 of 18

4	Replacement Strategy	Requires replacement after every operation	No replacement after operation
---	----------------------	--	--------------------------------

- 2 b) State the factors to be considered while selecting MCCB for motor protection.

Ans:

Factors to be considered while selecting MCCB for motor operation:

- i) Specifications of motor (Rated voltage & HP capacity)
- ii) Type of motor.
- iii) Cost of motor
- iv) Simplicity of protection
- v) Starting currents & Permissible overloads
- vi) Cost of protection schemes.
- vii) Breaking time.
- viii) Ambient conditions.

1 mark for
each of any
four factors
=
4 marks

- 2 c) Write the principle of distance relaying and mention the part of power system at which this type of protection is used.

Ans:

Principle of Distance relaying:

In distance relaying the action of relay depends upon distance (or impedance) between the point where the relay is installed and the point of fault. It is nothing but an impedance relay. It is double actuating quantity relay with one coil is energized by voltage and other coil is energized by current. The relay operates when ratio (V/I) reduces below a set value. Since it protects a certain length of line, it is called as distance relay. In distance relay the ratio (V/I) is measured. The current gives operating torque and voltage gives restraining torque. Hence for values of 'Z' above certain settings, the relay does not operate.

3 marks

This type of protection is used for high voltage long distance transmission lines.

1 mark

- 2 d) Suggest the type of protection for the following abnormalities / faults on alternator:

- i) Thermal overloading
- ii) Stator winding faults
- iii) Earth faults on rotor winding
- iv) Inter-turn fault

Ans:

Sr. No	Type of faults / abnormality	Protection suggested
1	Thermal overloading	Thermocouples or resistance thermometer embedded in stator slots, effective cooling systems, stator overload protection with over current relays, thermal relay.
2	Stator winding faults	Biased differential protection, sensitive earth fault protection
3	Earth faults on rotor windings	Rotor earth fault protection by DC injection method, Rotor earth fault protection

1 mark for
each



Diploma in Electrical Engineering: Winter – 2015 Examinations

Subject Code: 17508 (SAP)

Model Answers

Page No: 7 of 18

4	Inter- turn fault	Inter – turn fault protection
---	-------------------	-------------------------------

2 e) Distinguish between ‘equipment earthing’ and ‘neutral earthing’.

Ans:

Sr. No.	Equipment earthing	Neutral earthing
1	Connection of the non-current carrying metallic parts of the electrical equipment to earth is called as equipment earthing.	Connection of the neutral point of three phase transformer, generators, motors etc. to earth is neutral earthing.
2	It is provided for protection of human being from electric shocks.	It is provided for eliminating arcing ground and over voltage surge.
3	It has nothing to do with stability	Stability of the system is increased.
4	Equipment earthing is provided through Pipe earthing, Plate earthing.	Neutral earthing is provided through solid earthing, resistance earthing and reactance earthing.
5	It does not provide any means for protection system against earth fault.	It provides suitable means for earth fault protection system.
6	It is an equipment earthing.	It is a source or system earthing.

1 mark for each of any four points
=
4 marks

2 f) Draw a typical waveform of lightning surge and explain it in detail.

Ans:

Lightning Surge:

Basically lightning surge is defined as a sudden rise in voltage for very short duration on the power system. It is also called as transient voltage. Transients or surges are of temporary nature and exists for a very short duration (few hundred microseconds) but they are very harmful for the insulation of the various equipment connected in power system.

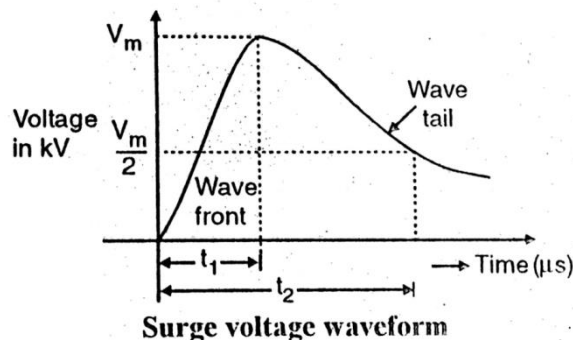

2 marks for diagram
+
2 marks for explanation
=
4 marks

Generally voltage surges are specified in terms of rise time t_1 and time t_2 to decay to half of the peak value.

3 **Attempt any FOUR of the following:**

4X4=16

3 a) Specifications of circuit breaker is given below
1500 Amp : 1000 MVA ; 33 kV : 3-phase, 3 secs.

Determine:

- i) Rated symmetrical braking current
- ii) Rated making current
- iii) Rated normal current
- iv) Short time rating

Ans:



Diploma in Electrical Engineering: Winter – 2015 Examinations

Subject Code: 17508 (SAP)

Model Answers

Page No: 8 of 18

- i) Rated normal current = 1500 amp (given)
- ii) Breaking capacity = 1000 MVA (given)
Rated symmetrical breaking current = Breaking capacity / ($\sqrt{3}$ x rated voltage)
= $1000 \times 10^6 / (\sqrt{3} \times 33 \times 10^3)$
= 17495.46 amps
- iii) Rated making current = 2.55 x Symmetrical breaking current
= 2.55 x 17495.46
= 44613.42 amps (peak)
- iv) Short time rating = 17495.46 amps for 3 sec.

1 mark for each answer

3 b) Describe with neat sketch the arc extinction in SF₆ circuit breaker.

Ans:

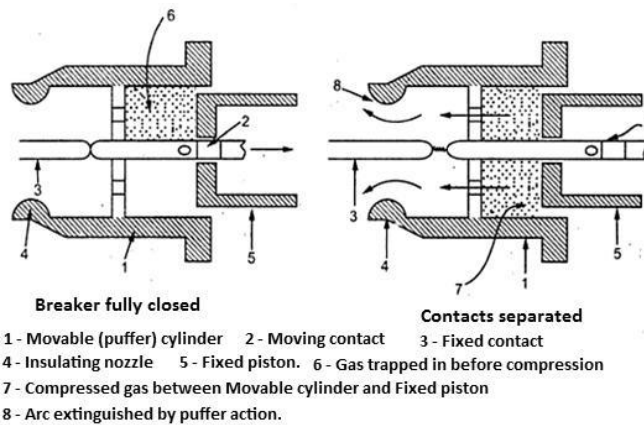

Single pressure puffer type SF₆ circuit breaker

2 marks for diagram
+
2 marks for explanation
=
4 marks

Gas is compressed by the moving cylinder and is released through the nozzle and rapidly absorbs the free electrons to extinguish the arc formed.

The moving cylinder (1) connected to moving contact (2) against the fixed piston (5). Due to relative motion between (1) and (5) the gas gets compressed in enclosure (6) and is released through nozzle for arc extinction. This happens by puffing action. At current zero the diameter becomes too small and arc gets extinguished.

OR

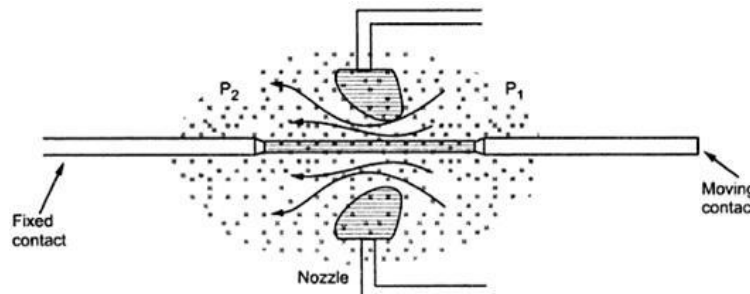

Double pressure type breaker:

Here the gas is made to flow from area P₁ to P₂ through a convergent-divergent nozzle. The flowing gas covers the arc. In the divergent section the speed of the gas is very high and carries away most of the heat and absorbs free electrons from the periphery of arc that results in the reduction of diameter of arc, which becomes nearly zero at current zero, leading to arc being extinguished. Finally the gas enters the contact space increasing the dielectric strength.



Diploma in Electrical Engineering: Winter – 2015 Examinations

Subject Code: 17508 (SAP)

Model Answers

Page No: 9 of 18

3 c) Define the terms related to protective relaying:

- i Time setting multiplier
- ii Pick up Current
- iii Reset current
- iv PSM

Ans:

- i) **Time Setting Multiplier** : The adjustment arrangement provided for setting the operation time of induction relay is known as Time Setting Multiplier.
- ii) **Pickup current**: The threshold value of operating current above which the relay operates. **OR**
It is the minimum current in the relay coil at which the relay starts to operate.
- iii) **Reset current**: The value of current below which the relay resets and comes back to its original state is called as reset current or dropout.
- iv) **Plug setting multiplier**: It is the ratio of fault current in relay coil to pick-up current.
$$PSM = (\text{Fault current in relay coil}) / (\text{Pickup current})$$

1 mark for
each
definition

3 d) Why is restricted earth fault protection provided for Delta / Star power transformer ? Draw the circuit diagram showing restricted earth fault protection for a Delta / star power transformer.

Ans:

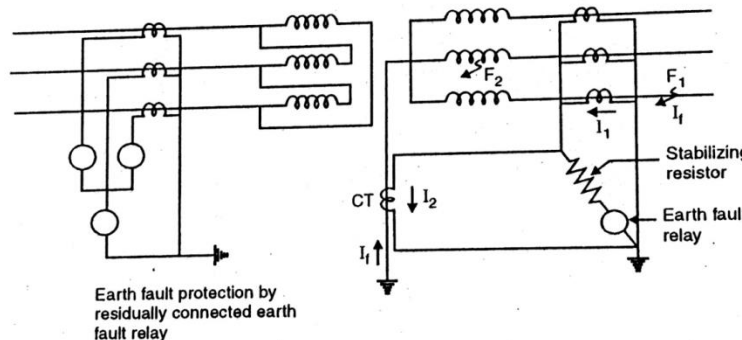

Restricted earth fault protection

In transformers, earth faults on secondary side are not reflected on primary side, when the primary winding is delta connected or has unearthed star point. In such cases, an earth fault relay connected in residual circuit of three CTs on primary side operates on internal earth faults in primary windings only. Because earth faults on secondary side does not produce zero sequence currents on primary side. Restricted earth fault protection may be then used for high speed tripping for faults on star connected earthed secondary winding of power transformer.

The restricted earth fault relay does not operate for earth fault beyond the protected zone of the transformer. When fault occurs very near to the neutral point of transformer, the voltage available for driving earth fault current is small. Hence fault current would be low. If the relay is set too sensitive to sense such faults, then it may operate for external faults and switching surges also.

Therefore relay setting is adjusted in such a way that it operates for earth fault

2 marks for
diagram
+
2 marks for
explanation
=
4 marks



Diploma in Electrical Engineering: Winter – 2015 Examinations

Subject Code: 17508 (SAP)

Model Answers

Page No: 10 of 18

current of the order of 15 % of rated winding current. Such setting protects restricted portion of the winding. Hence it is called as restricted earth fault protection.

- 3 e) What are the difficulties experienced while protecting the transformer by differential protection scheme? How are they overcome?

Ans:

- i) Difference in length of pilot wires on either side of relay:
The difficulty is overcome by connecting adjustable resistors to pilot wires
- ii) Difference in CT ratio:
This difficulty is overcome by using biased differential relay.
- iii) Magnetizing current inrush:
This difficulty is overcome by providing time lag of 0.2 Sec. in the relay, by this time the inrush current will vanish and relay does not trip unnecessarily. This problem can be overcome by using second harmonic restraint relay.
- iv) Phase difference between primary and secondary currents:
This difficulty is overcome by proper connections of CTs on both sides. e.g for delta-star connected transformer, CTs are connected in star-delta fashion.
- v) Tap changing affects the ratio of transformer:
This problem is overcome by adjusting the turns ratio of CT accordingly.

Any four
1 mark each

- 4 (A) Attempt any THREE of the following:

3X4=12

- 4 (A) a) Draw the construction diagram of ELCB and explain how ELCB gives protection against earth leakage fault.

Ans:

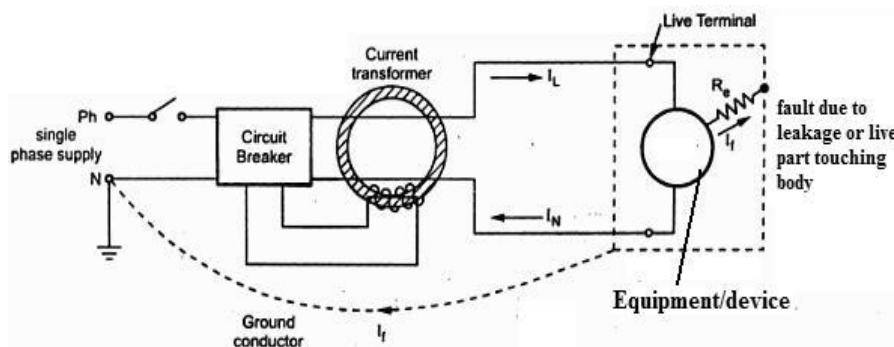

2 marks for
diagram

Earth leakage circuit breaker is a safety device used in electrical installations with high earth impedance to prevent shocks and disconnect power under earth fault conditions. It works on principle of relaying when the current in the earth path exceeds a set value. ELCB is used for protection against electric leakage in the circuit of 50 Hz or 60 Hz, rated voltage single phase. 240 V, 3-ph. 440V. Rated current up to 60 Amp. When the earth fault occurs, the ELCB cuts off the power within the time of 0.1 sec. automatically to protect personnel.

2 marks for
explanation

Under normal conditions $(I_L - I_N) = I_f$ is very low or nearly zero. The CT surrounding the phase and neutral senses the differential current under earth fault and actuates the CB to operate (open). The difference current I_f through fault path resistance R_e is the leakage to earth. If this value exceeds a preset value, then the CB opens. Normally it is around 35 mA for tripping in domestic installations with tripping time being as low as 25 msec.



Diploma in Electrical Engineering: Winter – 2015 Examinations

Subject Code: 17508 (SAP)

Model Answers

Page No: 11 of 18

- 4 (A) b) A 20 MVA, 11 kV, 3-phase star connected alternator is protected by differential protection scheme. The star point is earthed through a resistance of 5 ohm. If CTs have a ratio of 1000/5 and the relay is set to operate when there is an output balance current of 1.5 amp. Calculate the % of each phase of stator winding which is left unprotected.

Ans:

Let X % of the winding is unprotected.

Earthing resistance $r_e = 5$ ohm

$V_p =$ voltage /phase = $11 \times 10^3 / \sqrt{3} = 6350.85$ V

The minimum fault current to operate the relay = $(1000 / 5) \times 1.5 = 300$ amp..... 1 mark

EMF induced in X % of stator winding = $V_p (X / 100)$
= $63.5085 X$ volts..... 1 mark

Earth fault current that will flow because of voltage induced in X % of winding
= $63.5085 X / r_e = 63.5085 X / 5$
= $12.7 X$ amp..... 1 mark

This current should be equal to minimum fault current required to operate the relay.

$12.7 X = 300$

Percentage of winding left unprotected = $X = 23.62$ % 1 mark

- 4 (A) c) Describe with a neat connection diagram the operation of differential protection scheme provided for bus bars.

Ans:

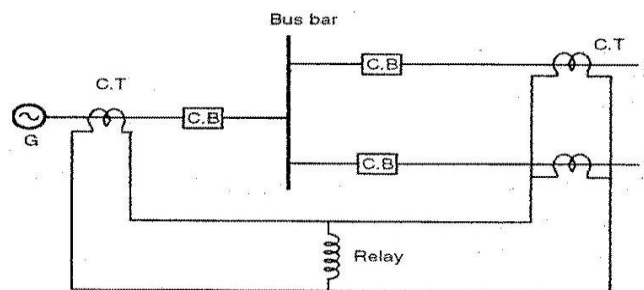

Differential protection of bus bar

2 marks for diagram

Differential protection Scheme for bus bar:

Under normal conditions the sum of the currents entering the bus bar zone is equal to those leaving it and no current flows through the relay coil. If a fault occurs within the protected zone, the currents entering the bus will no longer be equal those leaving it. The difference of these currents will flow through the relay coil causing opening of circuit breaker.

2 marks for explanation

- 4 (A) d) What are harmful effects of travelling waves and name the protective devices used for protection against travelling waves?

Ans:

Harmful effects of Travelling Waves:

- i) Insulation of windings may be damaged due to internal flash over by high peak voltage of the voltage surge.
- ii) Inter- turn insulation of transformer may be damaged due to steep front of surge wave.
- iii) Insulators of the terminal equipment may be damaged due to external flash over.
- iv) Resonance and high voltage causes oscillations in the electrical equipment.

1 mark for each of any two points



Diploma in Electrical Engineering: Winter – 2015 Examinations

Subject Code: 17508 (SAP)

Model Answers

Page No: 12 of 18

Protective devices used:

- i) Lightning arresters
- ii) Arcing horns across string insulators
- iii) Surge diverters and absorbers
- iv) Earthing Screens

1 mark for each of any two devices

4 (B) Attempt any ONE of the following

1X6=6

- 4 (B) a) (i) Describe the behavior of three phase induction motor under single phasing.

Ans:

Behaviour of three-phase Induction motor under single phasing:

When one of the supply lines of the three phase supply connection gets disconnected then this situation is known as single phasing. Under this condition, motor continues to operate on a two phase supply. If the motor is loaded to its rated full load it will draw excessive current on single phasing. Single phasing may cause extreme magnetic unbalance, reduction in torque and over- heating due to negative phase sequence current. This condition may cause damage to the motor. Hence protection against single phasing is necessary.

3 marks

- 4 (B) a) ii) Describe with circuit diagram the working of single phase preventer.

Ans:

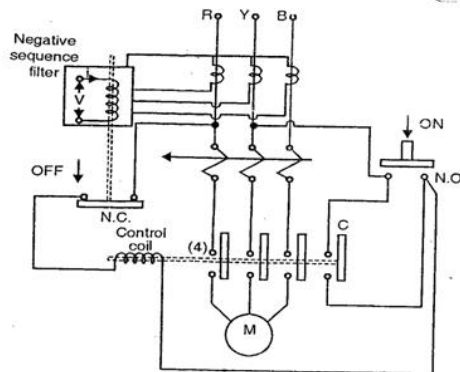

2 marks for diagram

Single phasing preventers are generally used for small / medium capacity motors. Single phasing preventers are connected in secondaries of line CTs. These mainly contains a negative sequence filter . The output of negative sequence filter is fed to the level detector, which further sends tripping command to starter or CB . Thus it protects motor from damage.

1 mark for explanation



Diploma in Electrical Engineering: Winter – 2015 Examinations

Subject Code: 17508 (SAP)

Model Answers

Page No: 13 of 18

- 4 (B) b) Describe with neat diagram, the time graded over current protection of transmission line. State its drawbacks.

Ans:

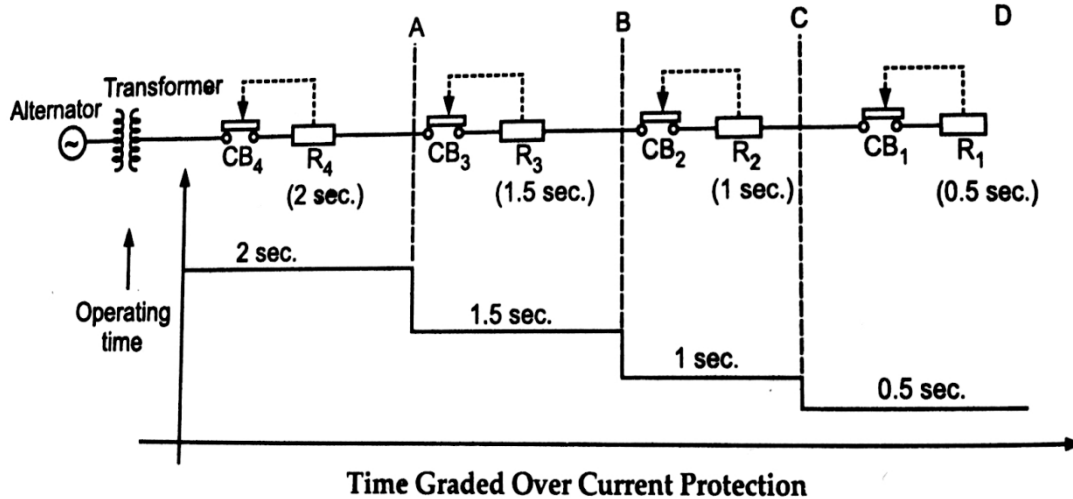

2 marks for diagram

The line or feeder is divided into number of sections. Overcurrent relays are provided for each section. On occurrence of fault in any section, the respective relay operates and gives trip signals to circuit breaker. The circuit breaker then opens & isolates the faulty part.

2 marks for explanation

In the figure the entire transmission line is sectionalized (i.e. AB, BC, CD). Definite time relays are used for individual section which gives trip signal to respective circuit breaker.

Drawbacks :

- If the line is having large length or more number of sections, the operating time near supply side point is more.
- If a fault, say line to ground fault occurs in the section near the transformer or source that cause amount of fault current more because line impedance is less.
- It is not suitable for longer feeder length.

1 mark for each of any two drawbacks

- 5 Attempt any FOUR of the following:

4X4=16

- 5 a) Explain the arc extinction methods in circuit breakers.

Ans:

Two main methods of arc extinction:

- High resistance method
- Zero current extinction

High resistance method:

Arc path resistance is increased to reduce the current to low values while interrupting the arc.

$$\text{Arc resistance} = V_{\text{arc}} / I_{\text{arc}}$$

The arc resistance mainly increased by three methods given below:

- Lengthening of the arc by arc runners
- Splitting the arc by arc splitters
- Arc cooling

2 marks for each method



Diploma in Electrical Engineering: Winter – 2015 Examinations

Subject Code: 17508 (SAP)

Model Answers

Page No: 14 of 18

Current zero or Low Resistance Method:

This method is employed in a.c. circuit breakers since the ac passes through zero 100 times /second in 50 cycle current wave. When current wave passes through every zero, the arc vanishes for a brief moment. However the arc restrikes again with the rising current waves.

In this method, at current zero instant, fresh unionized medium is introduced between the space in between the contacts. Due to this medium deionization effect takes place. The dielectric strength of the contact space increases to such an extent that the arc does not continue after current zero.

- 5 b) Describe with neat sketch the principle of operation of vacuum circuit breaker.

Ans:

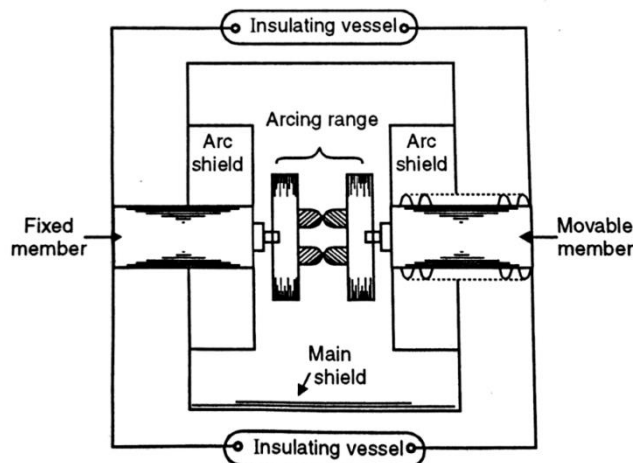

Vacuum circuit breaker

2 marks for diagram

Principle of operation :

During the operation of the breaker, the moving contact separates from the fixed contact resulting in arching between them. The arc consists of metal ions of surface of the contacts. The arc gets extinguished quickly and vacuum has good recovery of dielectric strength. The arc extinction occurs at a small vacuum gap of about 0.6 to 0.7 cm.

2 marks for explanation

- 5 c) Describe with neat sketch the operation of induction type directional overcurrent relay.

Ans:

Induction type directional overcurrent relay:

Under normal operating conditions, power flows in the normal direction in the circuit. Therefore directional power relay does not operate and overcurrent element remains unenergized

However, when a short circuit occurs, and if the current or the power flows in the reverse direction, the disc of the upper element rotate to bridge the fixed contacts 1 & 1'. This completes the circuit for over current element. The disc of this element rotates and moving contact attached to its closes the trip circuit. This operates circuit breaker which isolates the faulty section.

1 mark for description



Diploma in Electrical Engineering: Winter – 2015 Examinations

Subject Code: 17508 (SAP)

Model Answers

Page No: 15 of 18

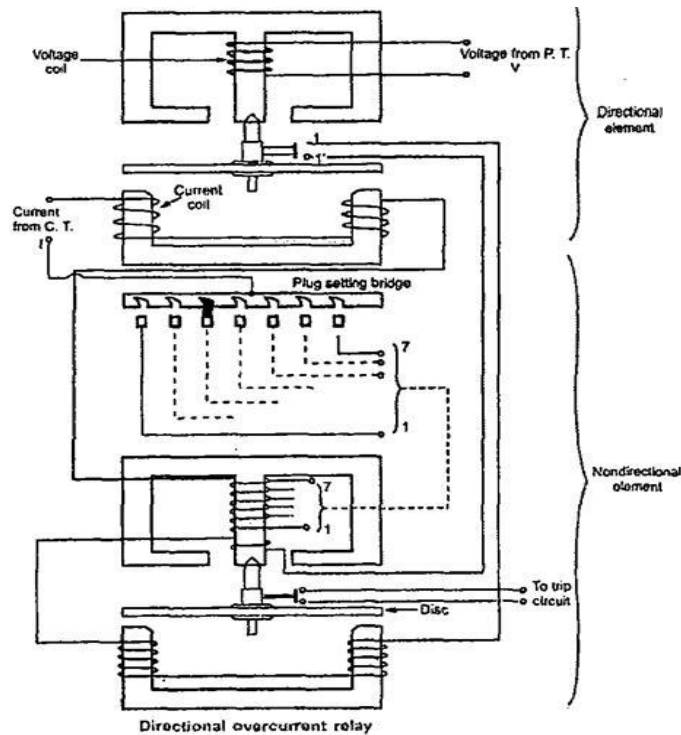

3 marks for diagram

- 5 d) What is burden of CT? How is it specified? Why the secondary of CT should not be open circuited when energized?

Ans:

C.T. Burden: It is defined as load connected across C. T. secondary.

It is specified in VA (Volt –Ampere)

If C.T. secondary is kept open, the secondary current becomes zero, the secondary mmf also becomes zero. The working flux therefore increases and core gets saturated. Due to this, voltage induced in secondary rises to very high value. Also the primary gets over heated. The peak value of secondary emf may be several times the rms value. This may cause danger to person working on secondary side of CT.

1 mark for definition
1 mark for specification

2 mark for reason

- 5 e) Describe with block diagram the operation of microprocessor based over current relay.

Ans:

Microprocessor based over current relay:

The ac voltage proportional to the load current is converted in to dc through a precision rectifier. Thus the microprocessor accepts d. c. voltage proportional to the load current. The schematic diagram is shown in the figure. The output of rectifier is fed to the multiplexer. The output of multiplexer is fed to the A/D converter to obtain the signal in digital form. The A/D converter ADC 0800 has been used for this purpose. The microcomputer sends signals to the ADC for starting the conversion. The microcomputer reads the end of conversion signal to examine whether the conversion is over or not. As soon as conversion is over, the microcomputer reads the current signal in digital form and then compares it with the pickup values. The microcomputer first determines the magnitude of the fault current and then selects the corresponding time of operation from the look up table. Then it goes in delay subroutine and sends a trip signal to the circuit breaker after the predetermined time delay.

2 marks for explanation



Diploma in Electrical Engineering: Winter – 2015 Examinations

Subject Code: 17508 (SAP)

Model Answers

Page No: 16 of 18

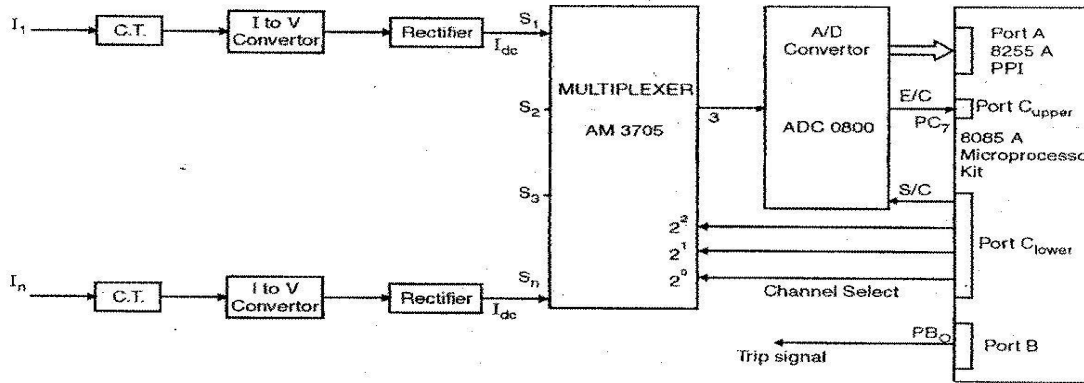

Schematic diagram of microprocessor based over current relay

2 marks for diagram

5 f) State the four advantages of static overcurrent relay over electromagnetic relay.

Ans:

Advantages:

- 1) Low power required hence less burden.
- 2) No motional parts hence bouncing, friction, erosion, arcing etc eliminated.
- 3) Not affected by gravity, may be used in any position.
- 4) Improved selectivity as resetting and over shoot times are reduced.
- 5) Lower operating times.
- 6) One static relay can be used for multiple purposes.
- 7) Higher torque /weight ratio.
- 8) Compact.
- 9) Good discriminating characteristics and reliability.
- 10) Suitable for reliable remote operation with PLCC.
- 11) Can be programmed as required.

1 mark for each of any four advantages

6 Attempt any FOUR of the following:

4X4=16

6 a) With a neat sketch, explain the operation of voltage balanced differential relay.

Ans:

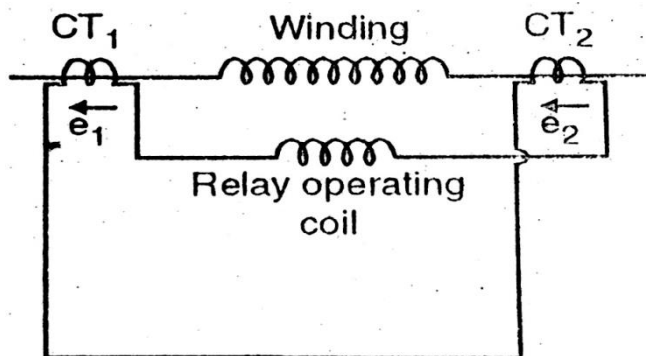

2 marks for diagram

Voltage balance differential Relay

Voltage Balanced Differential Relay:

Here two similar CTS are connected at either end of the element to be protected by means of pilot wires. The secondaries of CTs are connected in series with a relay in



Diploma in Electrical Engineering: Winter – 2015 Examinations

Subject Code: 17508 (SAP)

Model Answers

Page No: 17 of 18

such a way that under normal conditions their induced e.m.f. s are in opposition. Under healthy conditions, because of equal incoming and outgoing currents, the secondary voltages of two CTs are balanced against each other and no current flows in relay operating coil. When a fault occurs in the protected zone, the currents in two primaries will differ and their secondary voltages will also differ causing a current to flow through relay operating coil and relay operates.

2 marks for explanation

- 6 b) How are the negative phase sequence currents setup in an alternator? Suggest the protective scheme for the same.

Ans:

Unbalanced loading on alternator mainly causes the negative sequence currents which generate the negative sequence components of magnetic fields. These fields rotate in opposite direction of the main field and induce emfs of double frequency in rotor winding causing overheating.

2 marks

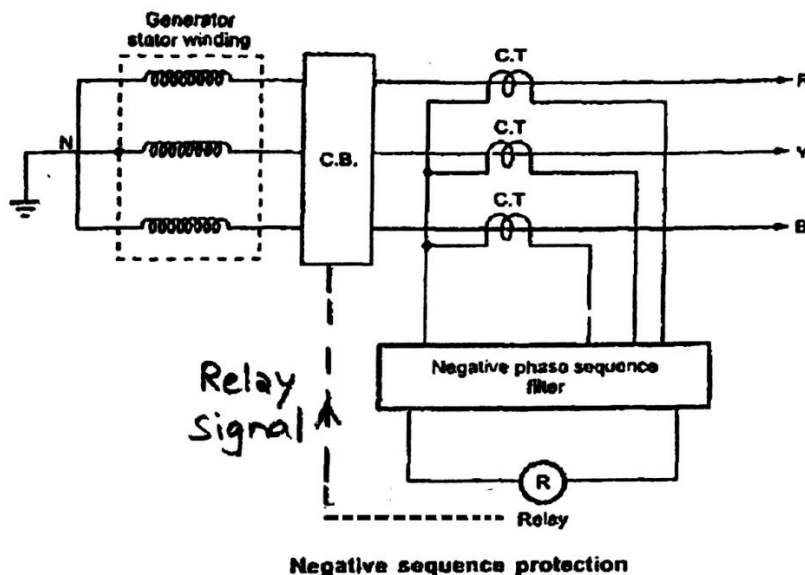

1 mark for figure

Protective Scheme:

The negative sequence filter in above figure detects presence of negative sequence component due to unbalance and operates the relay.

1 mark

- 6 c) Suggest the type of protection necessary for following abnormal condition / fault in case of power transformer:
- Over heating
 - Faults in tap changer
 - Earth faults
 - Inter- turn fault

Ans:

- Over Heating – i) Temperature relay (sound alarm)
ii) Thermal over load relay
- Faults in tap changer – i) Percentage differential protection
ii) Buchholz relay
iii) High speed high set over current relay
- Earth faults – i) Earth fault relay

1 mark for each bit (max. 4 marks)



Diploma in Electrical Engineering: Winter – 2015 Examinations

Subject Code: 17508 (SAP)

Model Answers

Page No: 18 of 18

- ii) Differential protection
4) Inter- turn fault – i) Buchholz relay
ii) Differential protection

- 6 d) What are the limitations of Buchholz relay in case of transformer protection? State the guidelines for the Installation of Buchholz relay on transformer.

Ans:

Limitations of Buchholz relay:

- i) Only the faults below the oil level are detected. 2 marks for
ii) Mercury switch setting should be very accurate otherwise even for vibration there each of any
can be a false operation. two
iii) The relay is slow operating type which is unsatisfactory. limitations
iv) They are not provided for transformers below 500 KVA because of economic reasons.

Guide lines for the installation of Buchholz relay on transformer:

- i) The arrow on the cover at the top of the relay should always point towards the oil conservator. 2 marks for
ii) The recommended angle of inclination of the Buchholz relay pipe work should each of any
be 3 to 9 degree two
iii) The Buchholz relay must initially be full off oil. Guidelines
iv) The pipe has no elbows and bends.
v) The pipe length between Buchholz relay and the tank should be at list 10 times internal diameter.

- 6 e) What are the requirements of transmission line protections? Also write about any two abnormalities occur in transmission lines.

Ans:

Requirements of transmission line protection:

- i) Faults on lines should be quickly detected to initiate actions to maintain system stability. 1 mark for
ii) For very long lines the protection system must be capable of identifying the fault each of any
location. two
iii) In the event of short circuit fault on the line, the circuit breaker nearest to it must requirement
operate to open the line, while the other circuit breakers remain closed.
iv) Adjacent circuit breakers should provide immediate backup protection in the event of failure of circuit breaker (nearest to fault) to operate.

Abnormalities in transmission lines:

- Transmission lines are being exposed to atmospheric conditions, the chances of fault occurring are due to: 1 mark for
i) Storms, each of any
ii) Falling of external objects on lines two
iii) Flash over resulting from dirt deposit on insulators etc. abnormalitie
s