



WINTER- 15 EXAMINATION
Model Answer

Subject Code: 17660

Page No: 1 of 29

Important Instructions to examiners:

- 1) The answers should be examined by key words and not as word-to-word as given in the Model answer scheme.
- 2) The model answer and the answer written by candidate may vary but the examiner may try To assess the understanding level of the candidate.
- 3) The language errors such as grammatical, spelling errors should not be given more Importance (Not applicable for subject English and Communication Skills).
- 4) While assessing figures, examiner may give credit for principal components indicated in the Figure. The figures drawn by candidate and model answer may vary. The examiner may give credit for any Equivalent figure drawn.
- 5) Credits may be given step wise for numerical problems. In some cases, the assumed constant Values may vary and there may be some difference in the candidate's answers and model answer.
- 6) In case of some questions credit may be given by judgment on part of examiner of relevant answer based on candidate's understanding.
- 7) For programming language papers, credit may be given to any other program based on equivalent concept..

Q1 Attempt any FIVE of the following:

20M

a) **Define sensors, signal conditioners, controllers and actuators in mechatronics system.**

Ans:

Sensor: -

01M

A sensor is an element in a measurements system that acquires a physical parameter and changes it into electrical signal.

E.g. Bellows, Thermocouple.

Signal conditioners:-

01M

The signal conditioner performs isolation, impedance matching, noise reduction, amplification, conversion of sensor output signal.

Actuators:-

01M

Actuators are the process of conversion of energy to mechanical form.

Controllers:-

01M

Controllers are the brains of control system operation and decide the kind of action taken in response to an error.

WINTER- 15 EXAMINATION
Model Answer

b) Distinguish between a transducer and a sensor.

Ans: (Any valid Four Points) **01M each**

Sr.no	Sensor	Transducer
1.	Acquires a physical parameter and changes it into a signal.	Conversion of energy from one form to another.
2.	It is known as sensing element.	It is known as a conversion element.
3.	It comes in direct contact with the measurand.	Not compulsory it should be in contact with the measurand.
4.	Eg. Bourdon tube Bellows.	Eg. L.V.D.T, strain gauge.

c) Give advantages, disadvantages of electronic controllers.(Two each)

Ans:-

Advantage :- (Any Two)

02M

- High initial cost.
- High accuracy.

Disadvantage :- (Any Two)

02M

- Long start-up period.
- Complex design.

d) Explain implementation of proportional hydraulic controller.

Ans:-

Diagram:-

02M

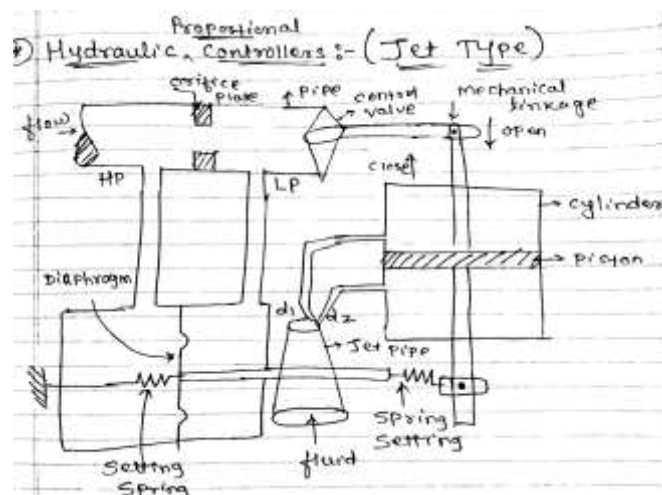

WINTER- 15 EXAMINATION
Model Answer

Subject Code: 17660

Page No: 3 of 29

Explanation:

02M

- When the jet pipe is moved towards right by the deviation the signal, the position moves to the right along with the feedback linkage whose motion acts to bring the jet pipe back to its neutral position.
- Thus for every unit deviation there is some fixed piston position that actuates the final element to certain opening that brings about the necessary correction in the measurement which is nothing but 'P' action control.

e) Explain the basic components of pneumatic systems with neat sketch.

Ans:

Diagram:-

02M

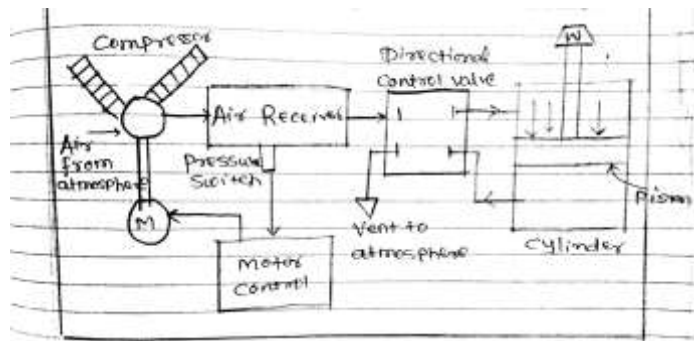

Components of pneumatic system:-

02M

- **Air filter:-** These are used to filter out the contaminants from the air
- **Compressor:-** The compressor is a mechanical device which converts mechanical energy into fluid energy.
- **Air cooler:-** During compression operation air temperature increases. Therefore coolers are used to reduce the temperature of the compressed air.
- **Dryer:-** The water vapor or moisture in the air is separated from the air by using a dryer.
- **Control valve:-** control and regulates the direction of flow and pressure etc.
- **Air actuator:-** Air cylinders and motors are used to obtain the required movements of direction flow.

f) List any four application of robot.

Ans:-

Application of robot:- (any 4)

01M each



WINTER- 15 EXAMINATION
Model Answer

Subject Code: 17660

Page No: 4 of 29

- Welding.
- Spray painting.
- Assembly and inspection.
- Medical filed.
- Loading and unloading of machine components

g) Give the block diagram of CNC based drilling machine.

Ans:

Note:-Any valid block diagram

Block diagram:-

04M

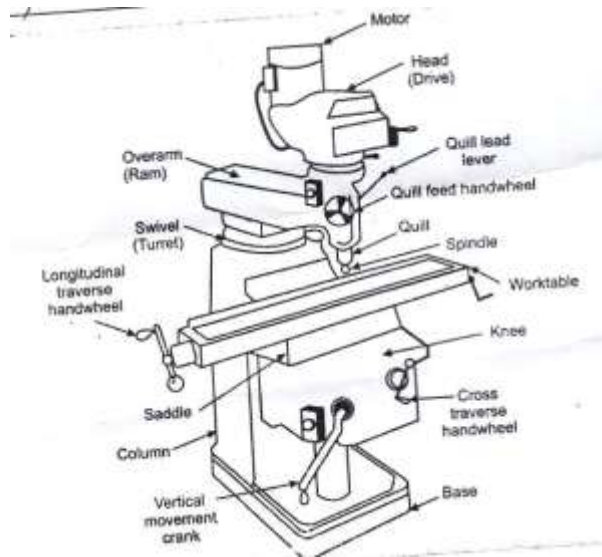

OR

WINTER- 15 EXAMINATION
Model Answer

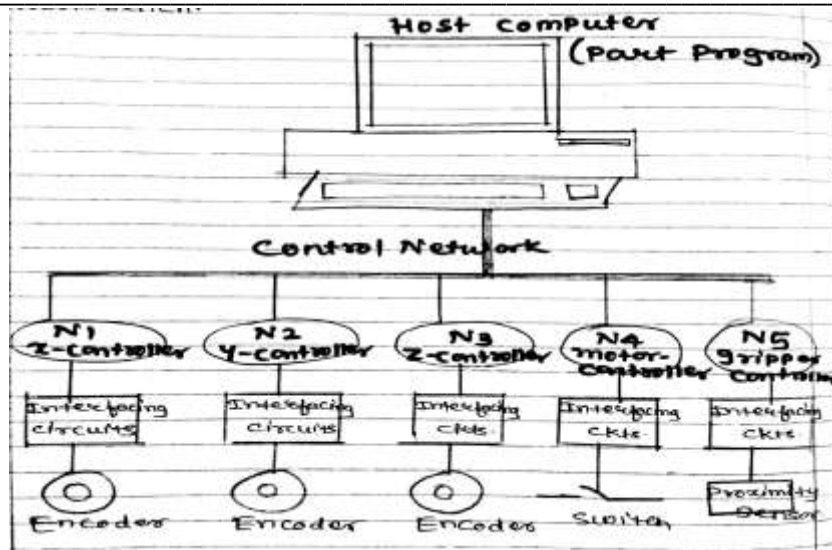

Q2) Attempt any TWO of the following:

16M

a) Explain in detail photoelectric sensor and Hall Effect sensor.

Ans:

Photo electronic sensor:

02M

- Photo electronic proximity sensors use a beam of light to detect the presence of objects that block or reflect the light beam.
- A beam of light passes from the light source and a photo transistor detects the light source.
- Most industrial photo electronic sensors use light emitting diodes for the light source and photo transistor is used to detect light radiation.
- There are two types of photo electronic sensor for sensing objects

Diagram:-

02M

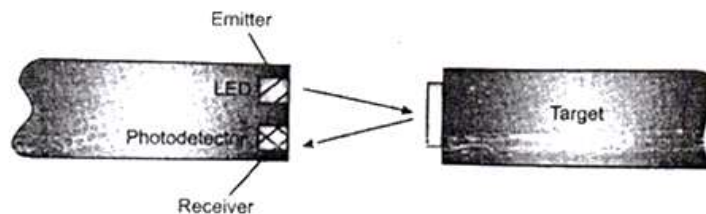

A **transmissive-type sensor** is used to measure the change in light quantity caused by the target crossing the optical axis as shown in Fig

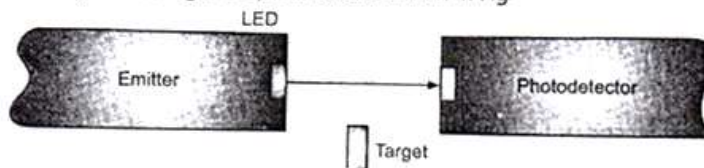

Hall Effect Sensors:

02M

WINTER- 15 EXAMINATION
Model Answer

Subject Code: 17660

Page No: 6 of 29

- When a beam of charged particles passes through a magnetic field. The beam deflected from its straight line path due to the forces acting on the particles.
- A current flowing in a conductor, such as a beam of moving charges and thus can be deflected by a magnetic field is called “ Hall Effect”

Diagram:-

02M

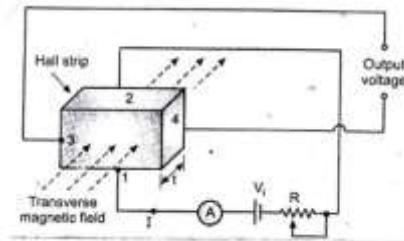

- The working principle of a Hall Effect sensor is that if a strip of conducting materials carries a current in the presence of a transverse magnetic field.
- The different of potential is produced between the opposite edges of the conductor.
- The magnetic of the voltage depends upon the current of magnetic field.

b) Explain solenoid valve with neat diagram. Give its principle of operation, advantages, disadvantages and applications.

Ans:

Diagram:

03M

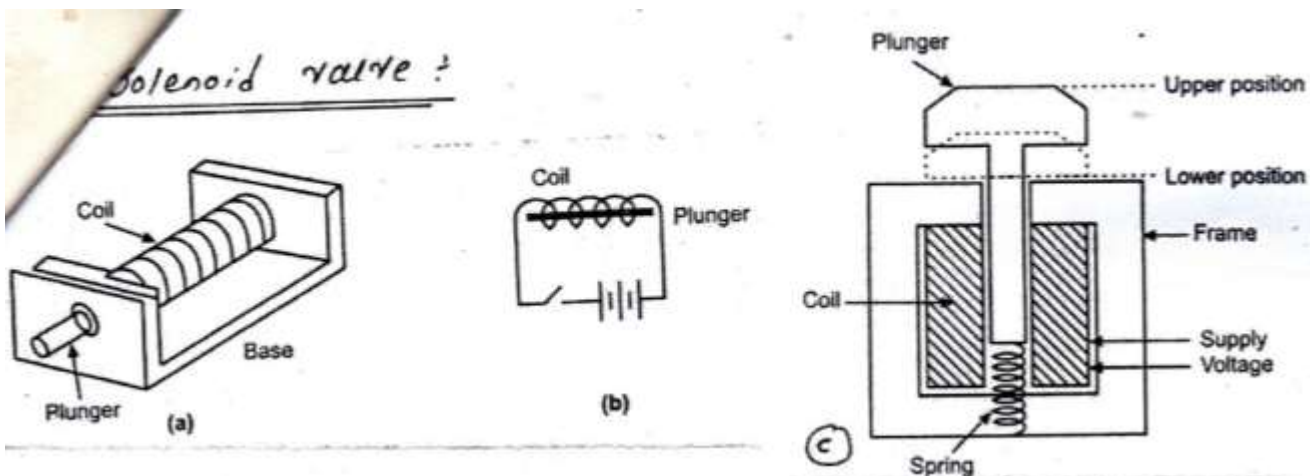

Principle of Operation:

02M

- In fig (b) shown above, when the coil is energized, the core is pulled inside the coil, and the amount of force by which the core is pulled mainly depends upon the number of coils and the amount of current flowing in the circuits.



WINTER- 15 EXAMINATION
Model Answer

Subject Code: 17660

Page No: 7 of 29

- The cut way section is shown in fig(c) the operation of the solenoid actuator.
- The spring return plunger is held in the upper position when the coil is electrically de-energized.
- When the voltage is applied to the solenoid frame magnetic field is produced in the solenoid frame.

Advantages: (any one)

01M

- Fast operation and high reliability.
- Long service life, compact design.
- Solenoid may partially open with higher voltage short pulse.

Disadvantages :- (any one)

01M

- Control must stay on during operation.
- Performance degrades when a solenoid gets hot (steam).
- Fast solenoid valves draw larger hold current.

Applications:- (any one)

01M

- Used in machinery devices and equipment such as refrigerators and automatic faucets.
- Used in heating system.
- Irrigation sprinkle system.

c) **What is Robotics? Draw the block diagram of robot and explain it.**

Ans:

Definition of Robotics:

01M

Robotics is a branch of Engineering that involves the conception design, manufacturing and operation of robots.

Block Diagram of Robot:

04M

WINTER- 15 EXAMINATION
Model Answer

Subject Code: 17660

Page No: 8 of 29

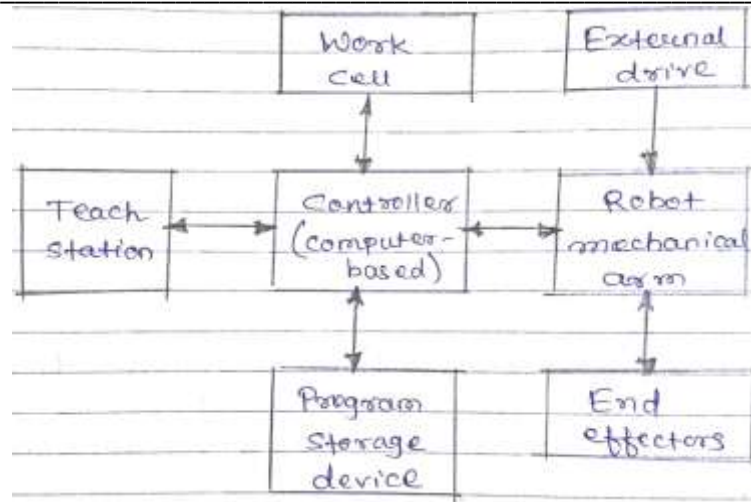

OR

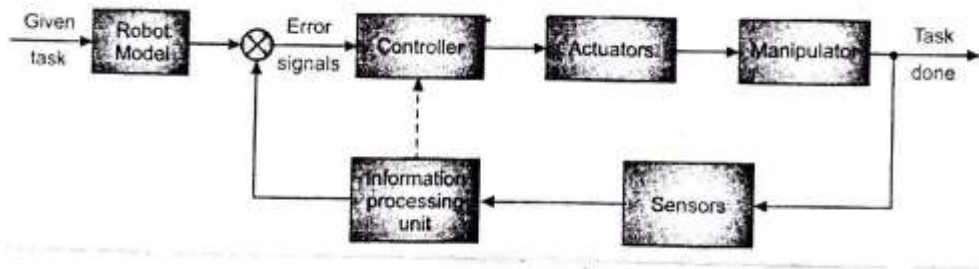

Explanation:

03M

- An Industrial robot has basic parts like arm, sensor, actuators, controllers etc.
- These subsystems communicate among them via interface, whose function consists basically of decoding the transmitted information from one medium to another.
- Fig. above shows block diagram of typical robotics mechanical system.
- The input is a prescribed task, which is defined earlier.
- The output of robotic mechanical system is the actual task, which is monitored by sensors.
- These sensors sense and transmit the information in the form of feedback signals.
- This is compared with the predefined task given to the controller.

Q3) Attempt any FOUR of the following:

16M

a) State advantages and disadvantages of Mechatronics system (Two each)

Ans:

[Any two advantages- 1 Mark each; any two

disadvantages- 1 Mark each]



Advantages of Mechatronics system: (Any 2)

01M each

- High level of integration.
- Increased functionality and better design.
- More use of electronics and software instead of mechanical function.
- Assumes responsibility for process and operation with little interference of operators.
- Uses artificial intelligence and intelligent process control.
- Multisensory and program environment □ High reliability and safety.
- Improved and less expensive controls.

Disadvantages of Mechatronics system: (Any 2)

01M each

- The initial cost is very high.
- The complicated design and system.
- The repair and maintenance is complex.
- Its replacement is difficult, that it is difficult to change old system to new system.

b) Explain the principle of inductive and capacitive sensor .Give two application of each

Ans: (Principle of each sensor-1M, Application of each sensor

(any two)-1M)

Capacitive Sensor: (Diagram is optional):-

01M

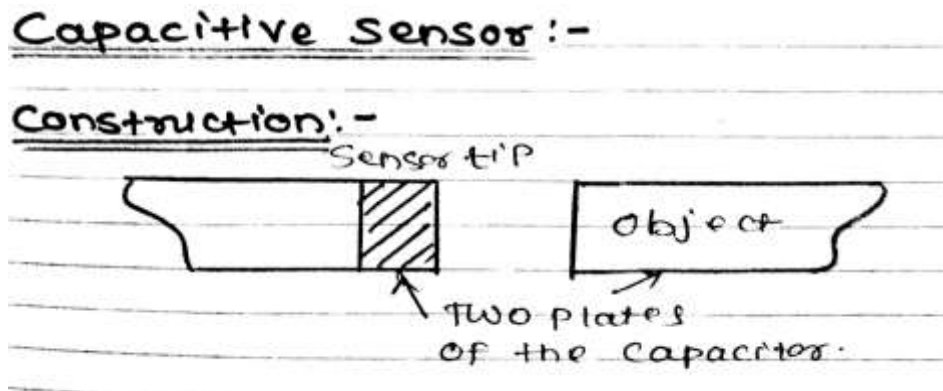

- Capacitive proximity sensor is a device actuated by both conductive and non-conductive materials. The pair of plates of a capacitor is separated by some distance.



WINTER- 15 EXAMINATION
Model Answer

Subject Code: 17660

Page No: 10 of 29

- Depending upon the separation, the capacitance measured will be changed. Therefore, proximity of the object can be detected if one of the plates of the capacitor acts as a switch and the other as the metal object whose proximity is to be detected.

$$C = \epsilon A/d$$

Where ϵ is permittivity of dielectric material .A is area of plate d is distance between plates.

Application: (Any 2)

1/2 M each

NOTE: any other application may consider.

- Measure proximity
- Position or displacement
- Humidity
- Fluid level
- Acceleration
- Human interface devices computer mouse.
- Digital audio players

Inductive sensor- (Diagram is optional):-

01M

- Inductive sensors use currents induced by magnetic fields to detect nearby metal objects. The inductive sensor uses a coil (an inductor) to generate a high frequency magnetic field as shown in Figure below.
- If there is a metal object near the changing magnetic field, current will flow in the object. This resulting current flow sets up a new magnetic field that opposes the original magnetic field.
- The net effect is that it changes the inductance of the coil in the inductive sensor. The sensors can detect objects a few centimetres away from the end

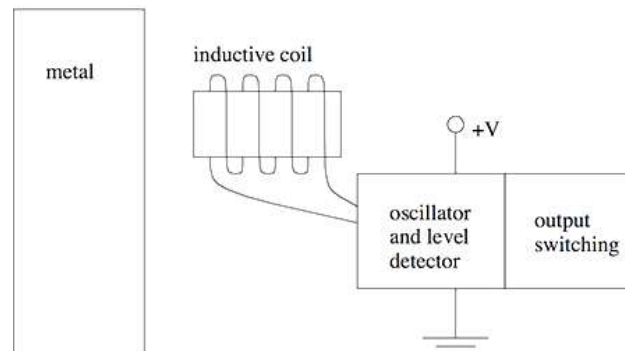

Application: Any 2

1/2 M each



WINTER- 15 EXAMINATION
Model Answer

Subject Code: 17660

Page No: 11 of 29

NOTE: any other application may consider.

- Metal detectors
- Traffic lights
- Car washes
- A host of automated industrial processes

c) Describe PLC program scan sequence.

Ans:

Description:-

03M

- PLCs operate by continually scanning programs and repeat this process many times per second. When a PLC starts, it runs checks on the hardware and software for faults, also called a self-test. If there are no problems, then the PLC will start the scan cycle. The scan cycle consists of three steps: input scan, executing program(s), and output scan.
- **Input Scan:** A simple way of looking at this is the PLC takes a snapshot of the inputs and solves the logic. The PLC looks at each input card to determine if it is ON or OFF and saves this information in a data table for use in the next step. This makes the process faster and avoids cases where an input changes from the start to the end of the program.
- **Execute Program (or Logic Execution):** The PLC executes a program one instruction at a time using only the memory copy of the inputs the ladder logic program. For example, the program has the first input as ON. Since the PLC knows which inputs are ON/OFF from the previous step, it will be able to decide whether the first output should be turned ON.
- **Output Scan:** When the ladder scan completes, the outputs are updated using the temporary values in memory. The PLC updates the status of the outputs based on which inputs were ON during the first step and the results of executing a program during the second step. The PLC now restarts the process by starting a self-check for faults.

Diagram:-

01M



WINTER- 15 EXAMINATION
Model Answer

Subject Code: 17660

Page No: 12 of 29

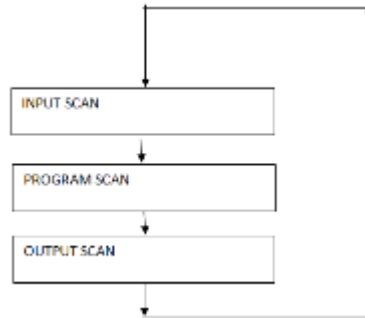

d) What is DC Motor? Give its working Principle with neat Diagram.

Ans:

Definition:

01M

A DC motor is any electrical machines that convert direct current electrical power into mechanical power.

Diagram:-

02M

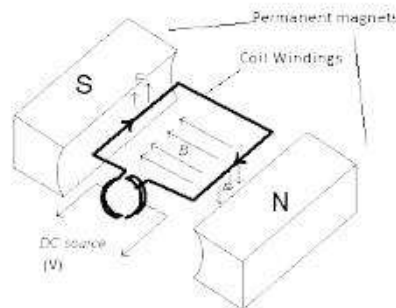

OR

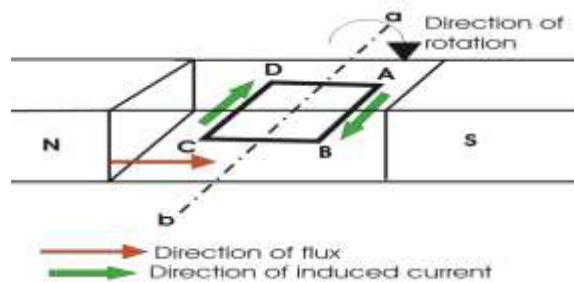

OR



WINTER- 15 EXAMINATION
Model Answer

Subject Code: 17660

Page No: 13 of 29

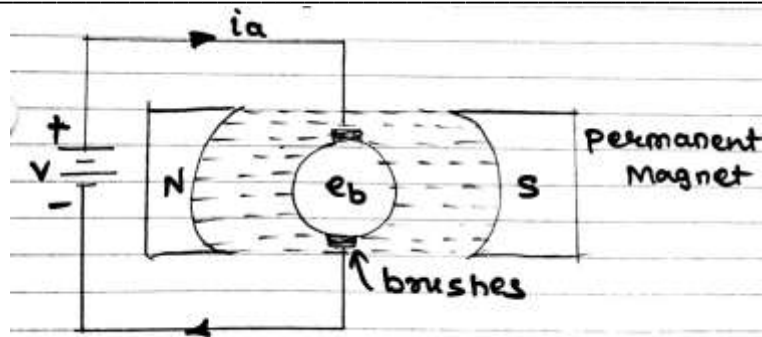

Working Principle:

01M

- It is based on the principle that when a current-carrying conductor is placed in a magnetic field, it experiences a mechanical force whose direction is given by Fleming's Left-hand rule and whose magnitude is given by

$$\text{Force, } F = B I l \text{ newton}$$

Where, B is the magnetic field in weber/m².

I is the current in amperes and

l is the length of the coil in meter.

- The force, current and the magnetic field are all in different directions. If an Electric current flows through two copper wires that are between the poles of a magnet, an upward force will move one wire up and a downward force will move the other wire down.
- The loop can be made to spin by fixing a half circle of copper which is known as commutator, to each end of the loop.
- Current is passed into and out of the loop by brushes that press onto the strips. The brushes do not go round so the wire does not get twisted. This arrangement also makes sure that the current always passes down on the right and back on the left so that the rotation continues. This is how a simple DC Electric motor works.

e) Define MEMS, List its application (any 2)

Ans:

Definition of MEMS:

02M

MEMs are Mechatronics systems that consist of mechanical elements and electronic circuits. A micro electromechanical system is an integration of mechanical elements, sensors, actuators and electronics on a common silicon substrate through micro fabrication technology.



WINTER- 15 EXAMINATION
Model Answer

Subject Code: 17660

Page No: 14 of 29

Applications [(any 2)]

01M each

NOTE:- Any additional application can consider because all the NANO field MEMS are use.

1. Adaptive Optics for Ophthalmic Applications
2. Optical Cross Connects
3. Air Bag Accelerometers
4. Pressure Sensors
5. Mirror Arrays for Televisions and Displays
6. High Performance Steerable Micro mirrors
7. RF MEMS Devices
8. Disposable Medical Devices
9. High Force, High Displacement Electrostatic Actuators
10. MEMS Devices for Secure Communications

f) Explain PLC based car parking barrier system.

Ans:

Explanation:-

02M

- Automatic car parking system allow to park maximum numbers of car in parking zone according to size of parking zone.
- In parking zone number of vehicle parked in parking zone is less than available parking space then automated parking system allow entering next car in parking zone.
- In parking zone number of vehicle parked in parking zone is equal to available parking space then automated parking system does not allow enter next car in parking zone.

Diagram:-

02M

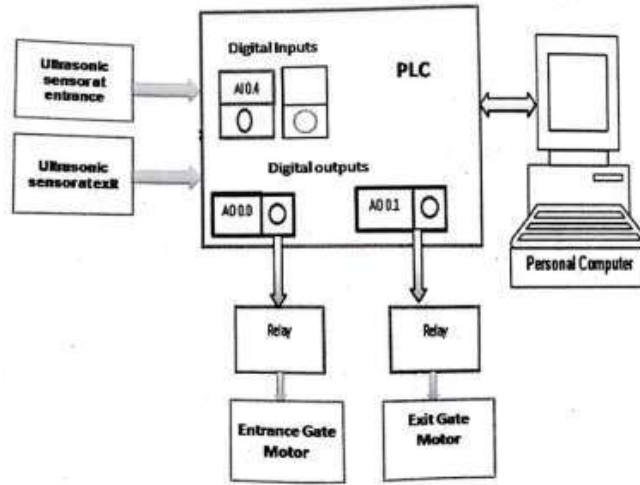

OR

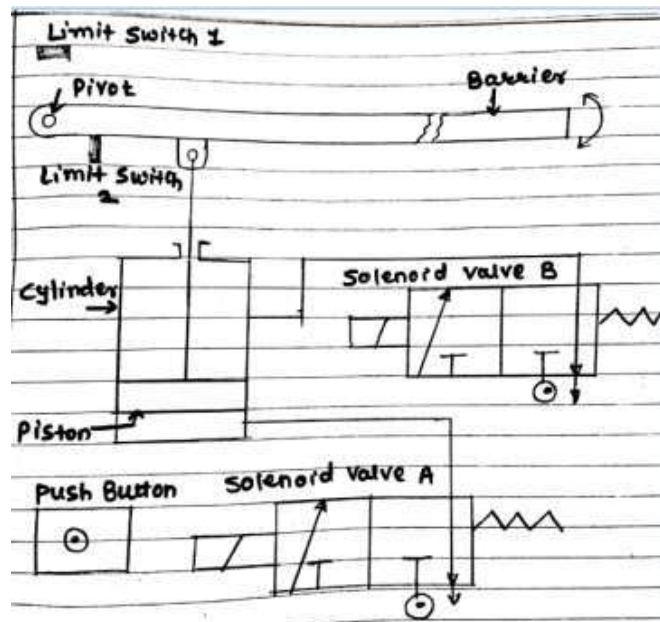

(Ladder diagram is optional)

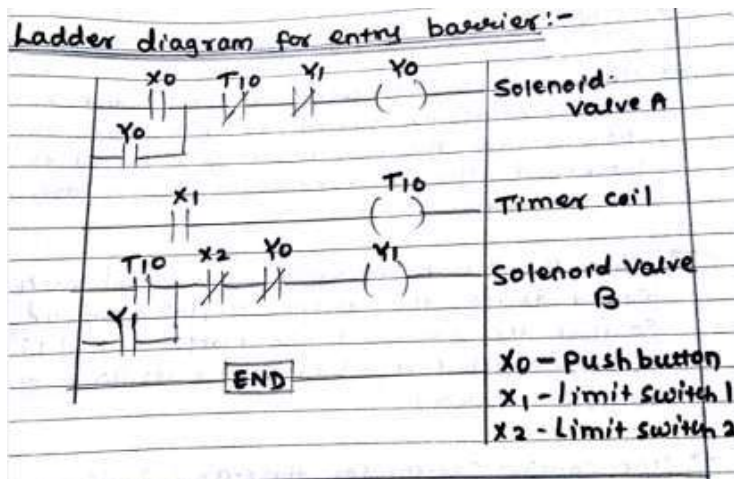

WINTER- 15 EXAMINATION
Model Answer

Q4. Attempt any TWO of the following

16M

a) Draw the block diagram of fuzzy logic controller explain function of each block

Ans:

Diagram:-

04M

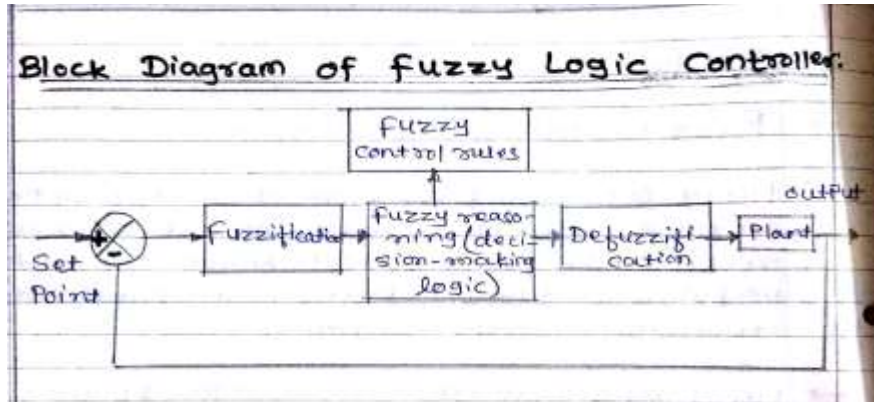

OR

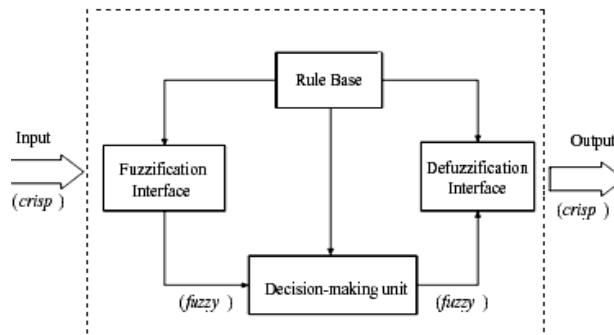

OR

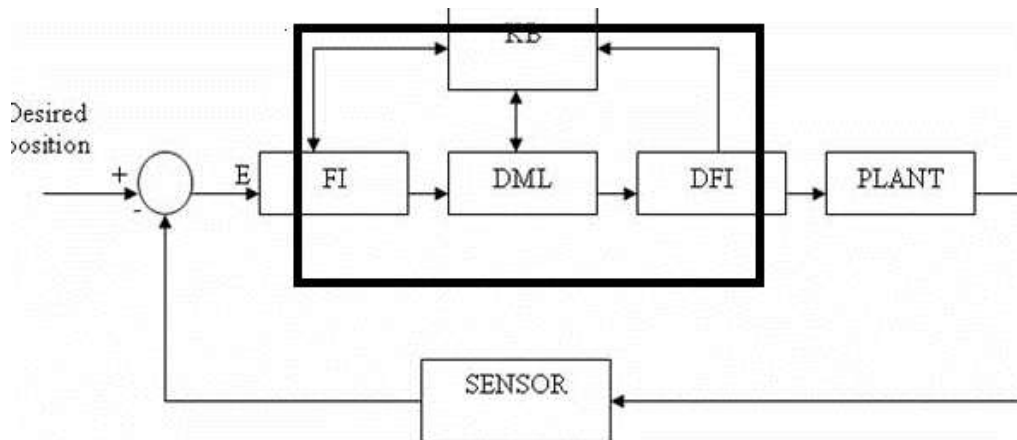

Explanation-

4M

1. Fuzzification:



WINTER- 15 EXAMINATION
Model Answer

Subject Code: 17660

Page No: 17 of 29

It is the action of transforming a given state as crisp input into fuzzy values by evaluating membership function for purpose to be used by a fuzzy interference mechanism. Membership function forms a crucial part in fuzzy rule base model because actually they only define Fuzzification of control variable in other word

- Fuzzification is the process of making a crisp quantity fuzzy.
- In the real world, hardware such as a digital voltmeter generates crisp data, but these data are subject to experimental error.
- Fuzzification based on rule base or by decision making with knowledge base
- Membership function is bell shaped or triangular or trapezoidal shape.

2. Fuzzy Interference:

Once membership function is found for each of variable an intelligent decision can be made to what output should be. This decision process is called interference this can be done knowledge base decision as well as rule base. This output then connected to Defuzzification block

3. Defuzzification:

Converts the fuzzy output of the inference engine to crisp using membership functions analogous to the ones used by the fuzzifier. A Defuzzification strategy is aimed at producing a non- fuzzy control action that best represent the possibility of an inferred fuzzy control action

b) State working principle of cam. List its types. Give four application of cam.

Ans:

Working principle of cam:

04M

- A cam is mechanical rotating machine element which is used for converting one motion in to another.
- A cam is a curved or grooved surface which mates with a follower and imparts motion to it.
- In general the cam may be rotating or oscillating whereas the follower may be rotating, reciprocating or oscillating.

Diagram: (Optional)

WINTER- 15 EXAMINATION
Model Answer

Subject Code: 17660

Page No: 18 of 29

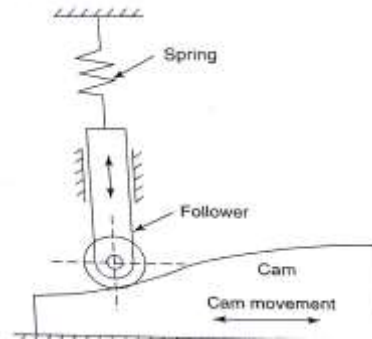

Types of cam:-

02M

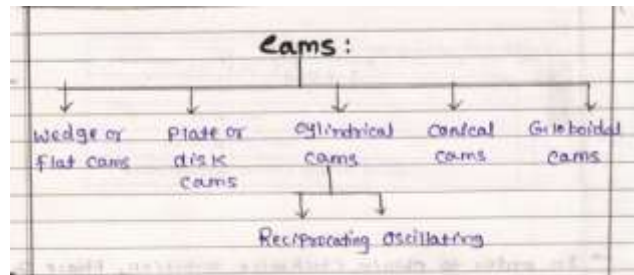

Applications of cam: (any four)

½ M each

- Automatic machines.
- IC engines.
- Machine tools.
- Printing control mechanisms.
- Spinning and weaving machineries.
- Textile machineries.
- Paper cutting machines.

c) **With neat block diagram explain microcontroller based antilock brake system.**

Ans:

An ABS is a system on motor vehicles which prevents the wheels from locking while braking stopping safely is one of the most important functions a motor vehicle can perform.

Diagram:

04M

WINTER- 15 EXAMINATION
Model Answer

Subject Code: 17660

Page No: 19 of 29

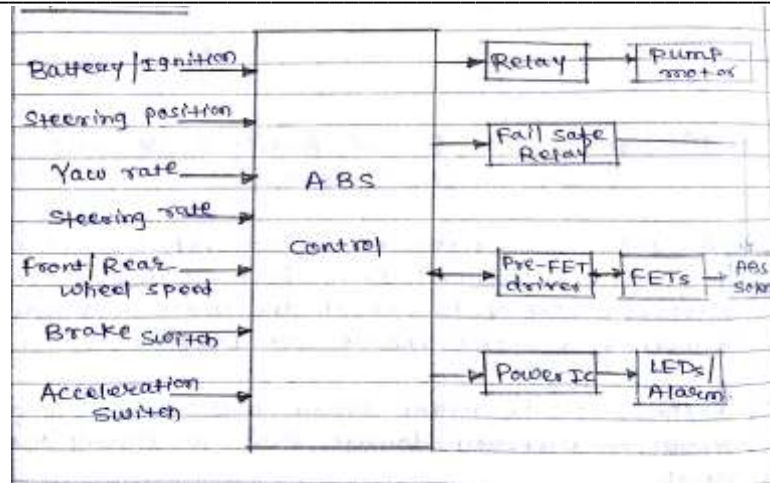

Explanation:

04M

- Failure of the brake system will almost invariably results in property damage, personal injury or even death.
- An ABS allow the driver to maintain steering control under heavy braking by preventing a skid and allowing the wheel to continue to roll forward and create lateral control, as directed by driver steering inputs.
- A typical ABS is composed of a central electronic unit, four speed sensors (one for each wheel) and two or more hydraulic valves on the brake circuit.
- The electronic unit constantly monitors the rotation speed of each wheel. The pulsed output from the wheel speed sensors goes to an electronic controller which monitors each wheels speed relative to the speed of the other wheels.
- As long as the brakes are not being applied and all of the monitored wheels are rotating at roughly the same speed, the system takes no action.
- If however the brakes are being applied and one or more monitored wheels suddenly beings to reduce speed indicating a loss of traction with load the controller then activates the antilock system.
- When it senses that any one of the wheels is rotating slower than the others, it moves the valves to decrease the pressure on the braking circuit, effectively reducing the braking force on that wheel.

Q.5 Attempt any FOUR of the following:

16M

a) What is mechatronics? Write its applications (Any two)

WINTER- 15 EXAMINATION
Model Answer

Subject Code: 17660

Page No: 20 of 29

Ans:

Mechatronics:

02M

Mechatronics is the synergistic integration of mechanical engineering with electronics and intelligent computer control in designing, manufacturing processes and production. It helps to develop atomized, reliable and efficient manufacturing/production systems to produce high quality products.

Applications of mechatronics (any two):

02M

- In automatic washing machine and dishwashers.
- In CD players, VCRs, camcorders.
- In document scanners.
- In IC manufacturing system.
- In robotics used in welding, nuclear inspection and robot manipulators.
- In fax and photocopier machines.
- In laser printers.
- In flexible manufacturing system.
- In air conditioners, elevator controls.
- In automotive mechatronics (in automobiles for outdoor locking, collision avoidance and ignition and antiroll systems etc.)

b) Draw and explain piezoelectric accelerometer.

Ans:

Diagram:-

02M

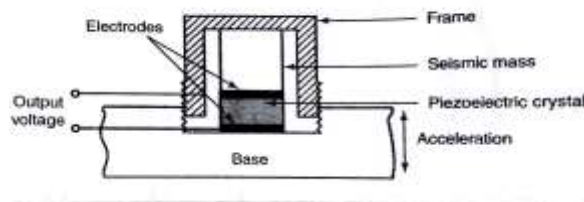

Explanation:-

02M

- The sensor consists of a piezoelectric crystal sandwiched between two electrodes and has a mass placed on it. The unit is fastened to the base whose acceleration characteristics are to be determined.
- The mass exerts a force on the crystal and a certain output voltage is generated. When the base is now accelerated downward, the internal reaction force on the base acts upward against the top of the frame.



WINTER- 15 EXAMINATION
Model Answer

Subject Code: 17660

Page No: 21 of 29

- This relieves stress on the crystal and from newton's second law, since the mass is a fixed quantity, the decreased in force is proportional to the acceleration.
- The resulting change in the output voltage is recorded and correlated to the acceleration imposed on the base.

c) Draw the ladder diagram for ON-OFF control of lamp.

Ans:

Diagram:- (Any correct ladder logic)

03M

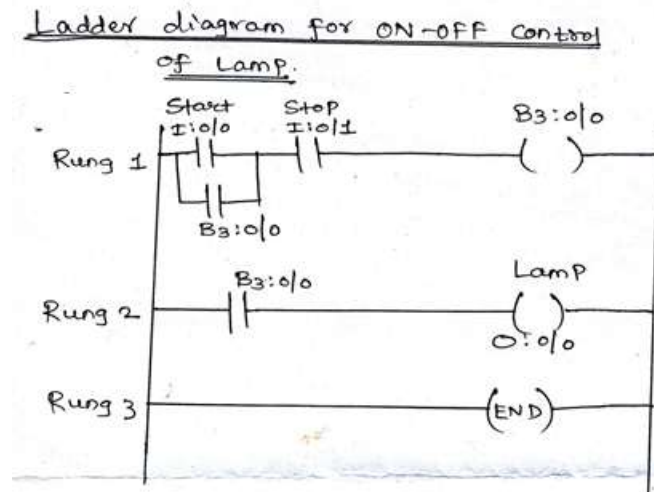

Explanation:-

01M

- Figure above shows simple ladder diagram for ON- OFF control of lamp.
- I: 0/0 is start button, as soon as it is pressed the contact gets closed and output binary bits B3 : 0/0 goes high (logic 1).
- As soon as B3 : 0/0 is high, lamp O:0/0 turns ON as shown in rung 2.
- When I:0/1 stop button is pressed, contact gets open and B3:0/0 goes low(Logic 0).
- When B3:0/0 goes logic 0, lamp named O:0/0 turns off.

d) Explain the types of gears.

Ans:

Types of Gears:- (Any four)

01M each

1. According to relative position of their axes:

i. **Parallel shafts:**

a. **Spur gears:**



WINTER- 15 EXAMINATION
Model Answer

Subject Code: 17660

Page No: 22 of 29

These gears have straight teeth parallel to the axes of the wheel.

b. Helical gears:

The teeth are curved and inclined to the shaft axis. Two mating gears have the same helix angle but have teeth of opposite hands.

c. Herringbone gears:

A double helical gear is equivalent to a pair of helical gears attached together; one has a right hand helix and other a left hand helix.

ii. Intersecting shafts:

a. Straight bevel gears:

The teeth are straight radial to the point of intersection of the shaft, axes and vary in cross section throughout their length. Usually, they are used to connect shaft at right angles.

b. Spiral bevel gears:

When the teeth of bevel gears are inclined at an angle to the face of the bevel, they are known as spiral bevel gears.



2. Non-parallel and non-intersecting gears:

a. Spiral gears or cross helical gears:

This gear have a helix cut on their periphery in such a manner that they have two non-parallel axes.

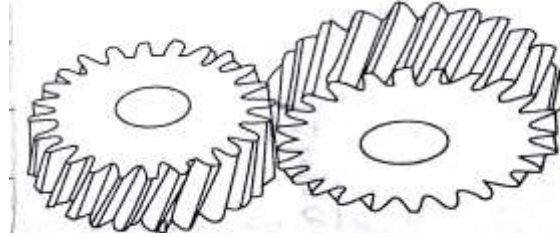

b. Worm gears:

Worm gears consist of a worm and worm wheel. A worm and worm wheel can be visualized as a screw and nut pair. They are used to transmit motion between non-parallel and non-intersecting shafts.

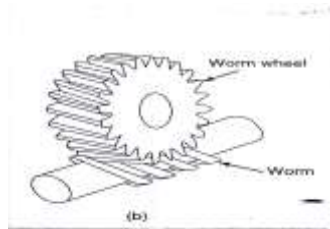

c. Hypoid gears:

Hypoid gears are similar to spiral bevel gears but the pinion is larger and stronger than a spiral pinion.

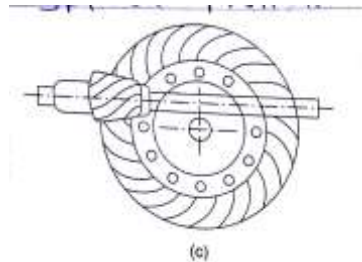

e) Explain the construction of spherical robot in brief.

Ans:

Construction diagram:

02M

WINTER- 15 EXAMINATION
Model Answer

Subject Code: 17660

Page No: 24 of 29

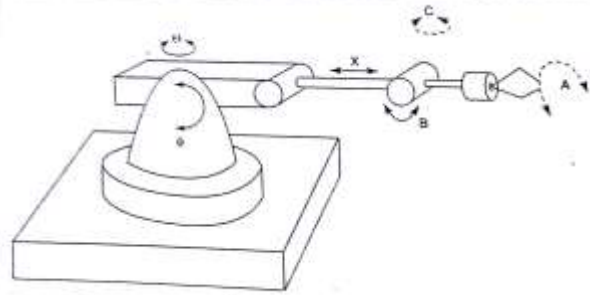

Explanation:

02M

- This is also known as a polar coordinate robot. This robot positions the wrist through two rotations and one linear actuations.
- As shown in above figure the orientation of the tool plate is achieved through three rotations in the wrist with toll of A, pitch of B and yaw of C.
- The robot is easy to control. For a given maximum reach of the robot, the work envelop is smaller than that of cylindrical robot.

f) Explain PLC based pick and place robot.

Ans:

Diagram:

02M

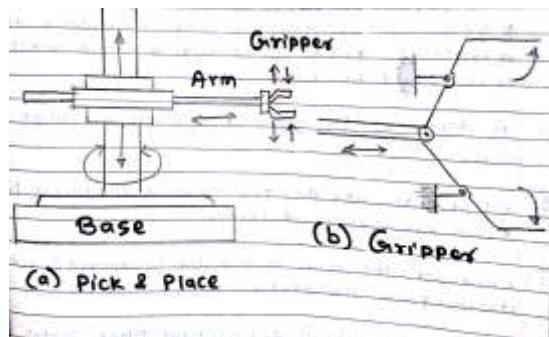

Explanation:

02M

- Figure above shows the basic form of a pick and place robot unit. The robot has three axes about which motion can occur.
- Rotation in a clockwise or anti-clock wise direction of the unit on its base.
- Arm extension or contraction and arm up or down.
- Gripper can open or close.
- These movements can be actuated by the use of pneumatic cylinders operated by solenoid controlled valves with limit switches to indicate when a motion is completed.

WINTER- 15 EXAMINATION
Model Answer

Subject Code: 17660

Page No: 25 of 29

- Thus clock wise rotation of the unit might result from the piston in a cylinder being extended and the anticlockwise direction by its retraction.
- Likewise the upward movement of the arm might result from the piston in a linear cylinder being extended and the downward motion from it retracting.
- The extension of the arm by the piston in another cylinder extending and its return movement by the piston retracting.
- The gripper can be opened or closed by the piston in a linear cylinder extending or retracting as shown in figure (b).

Q.6 Attempt any **FOUR** of the following:

16M

a) Explain LVDT accelerometer with neat diagram. Give its applications.

Ans:

(Diagram-1 1/2 M, Explanation-1 1/2 M, Applications

(two)-1/2 M each)

Diagram:

1 1/2 M

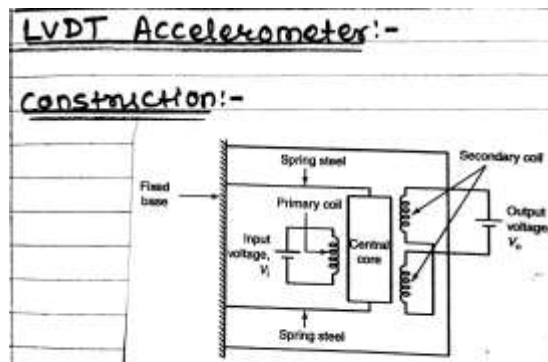

Explanation:

1 1/2 M

- The LVDT accelerometer consists of one primary and two secondary windings which are placed on either side of a central core. The two ends of the core are connected with a spring steel but these are already placed in a casing.
- If a core is exactly placed at the center, the voltage produced between primary and secondary windings will be exactly equal, this voltage is call as static field voltage.
- If any vibration occurs on the casing of the LVDT accelerometer, the core will either move upward or downward.



WINTER- 15 EXAMINATION
Model Answer

Subject Code: 17660

Page No: 26 of 29

- Owing to this, the voltage is induced in the secondary coil according to the movement of the core. Now the difference in voltage arises in the output terminal. This output voltage is directly proportional to the vibration or acceleration.

Applications:

½ M each

- It is used in steady state acceleration.
- It is used in low frequency measurements.

b) Explain torque measurement using strain gauge.

Ans:

Diagram:-

02M

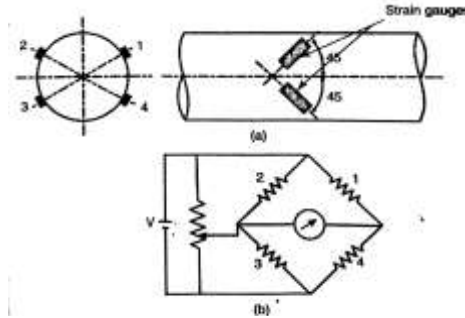

Explanation:

02M

- Torque transducers based on strain measurement are normally made by applying strain gauges to a shaft to measure the shear strain caused by torsion.
- The shear strain causes strains to appear at 45° to the longitudinal axis of the shaft. Therefore, the strain gauges must be placed precisely at 45° to the shaft axis as shown in figure above.
- The output is increased by using four gauges so that the adjacent arms have strain of opposite nature. Also this arrangement provides complete thermal compensation.
- For taking signals in and out the rotating shaft, slip rings and brushes are used.

c) Give general configuration of CNC system. Give advantages of CNC. (any two).

Ans:

(Diagram- 2 M, advantages (any

two- 1M each)

Diagram:

02M

WINTER- 15 EXAMINATION
Model Answer

Subject Code: 17660

Page No: 27 of 29

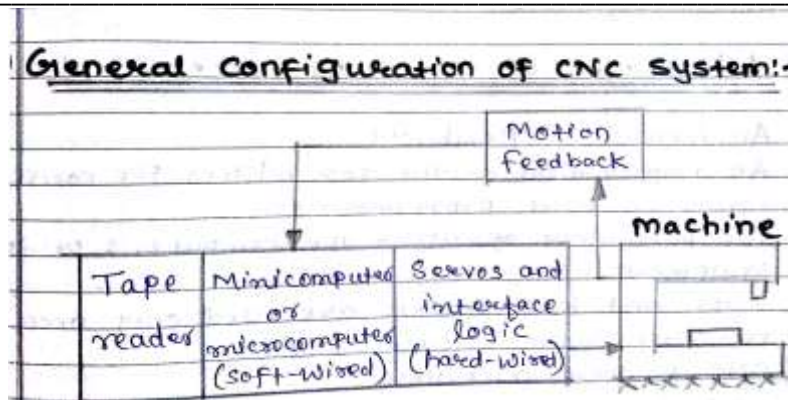

OR

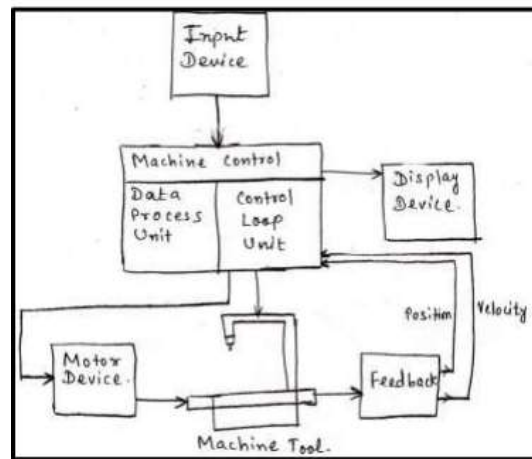

Advantages: (any two)

01M each

- An increase in flexibility.
- An improvement in the possibilities for correcting errors in part programming.
- The possibility of using the computers peripheral equipment.
- Tape and tape reads are used only once for resulting improved reliability.
- CNC is more compatible.
- CNC can accommodate the conversion of tapes prepared in units of inches to the international unit system.

d) What is actuator? Explain the principle of linear actuator.

Ans:

Definition of Actuator:

01M

An actuator is a type of motor that is responsible for moving or controlling a mechanism or system. It is operated by a source of energy, typically electric current, hydraulic fluid pressure, or pneumatic pressure, and converts that energy into motion.



Principle of linear actuator:

1 ½ M

A linear actuator is an actuator that creates motion in a straight line, in contrast to the circular motion of a conventional electric motor. Linear actuators are used in machine tools and industrial machinery, in computer peripherals such as disk drives and printers, in valves and dampers, and in many other places where linear motion is required. Hydraulic or pneumatic cylinders inherently produce linear motion. Many other mechanisms are used to generate linear motion from a rotating motor.

Diagram:-

1 ½ M

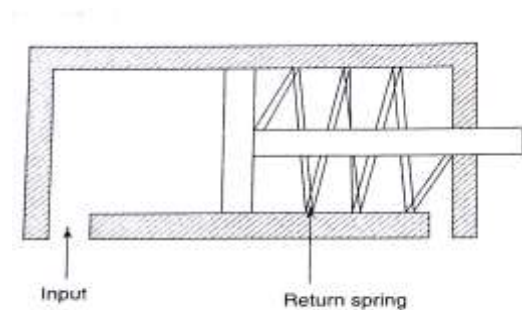

e) **Classify the robots based on workspace.**

Ans:

(Correct classification- 4 M)

Classification of robot:

- Material Processing robot
- Material handling robot
- Assembly robot
- Inspection robot

f) **Give the advantages and disadvantages of CNC based drilling machine. (Two each).**

Ans:

(Any two advantages-1M each, any two

disadvantages-1 M each)

Advantages: (Any two)

01M each

- An increase in flexibility.
- An improvement in the possibilities for correcting errors in part programming.
- The possibility of using the computers peripheral equipment.
- Tape and tape reads are used only once for resulting improved reliability.
- CNC is more compatible.



WINTER- 15 EXAMINATION
Model Answer

Subject Code: 17660

Page No: 29 of 29

-
- CNC can accommodate the conversion of tapes prepared in units of inches to the international unit system.

Disadvantages: (any two)

01M each

- Trained staff is required for operation of machine
- Part programming can be complicated for different operation to be carry out.
- The design of machine is complex.
- The initial cost of investment is very high.
- The repair and maintenance is complex.
- Its replacement is difficult.